

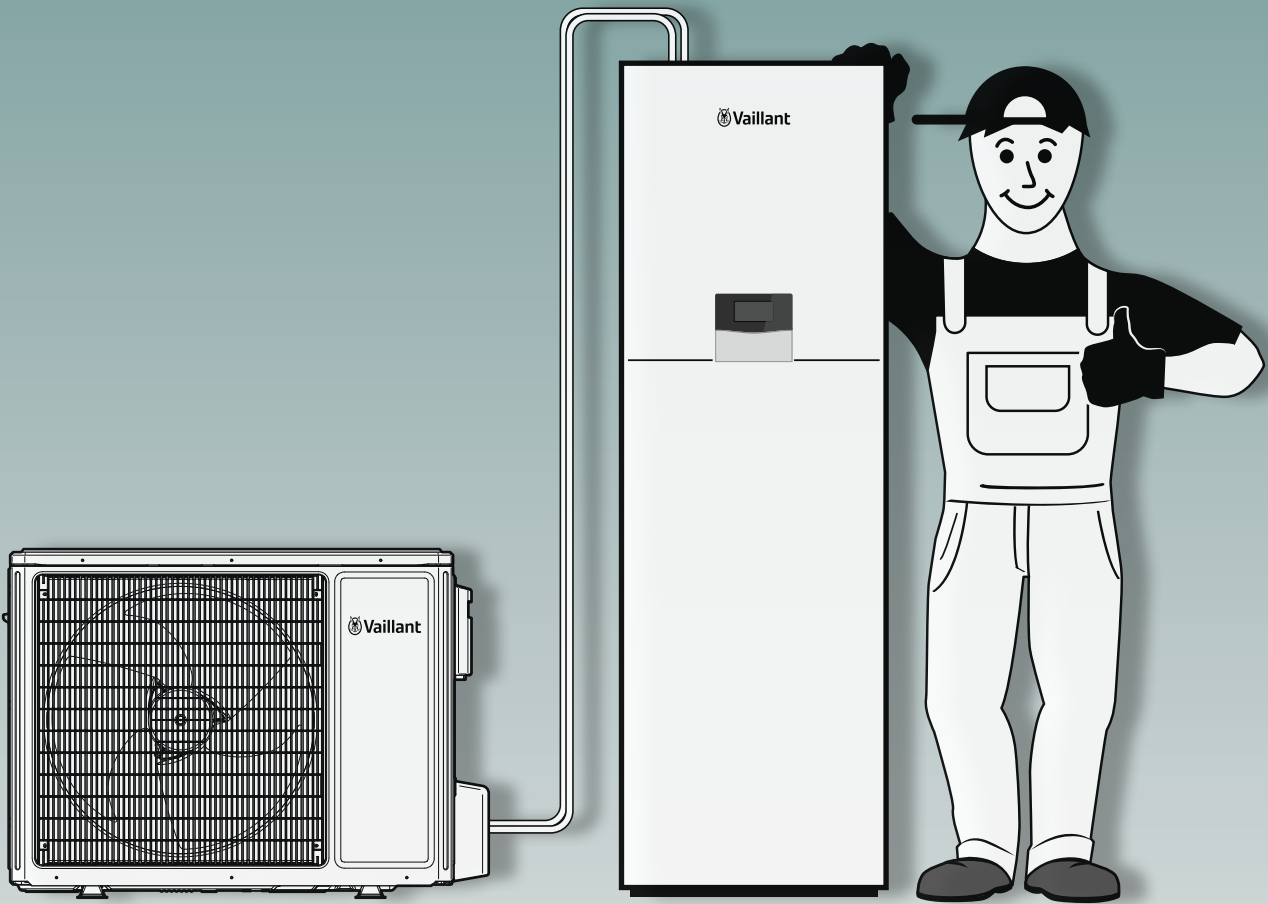

aroTHERM pure



Important Note:

This quick guide shall support the professional installer in planning, installing and commissioning the appliance. It shall on no account replace or modify the installation, operating and maintenance instructions delivered with the appliance which always have to be observed.

The non-observance of the instructions delivered with the appliance can lead to malfunctions of the appliance and can result in death or serious injuries. Some characteristics of the appliance shown in this quick guide may vary from those of the most current series version. Vaillant shall not be held liable for any damages or injuries arising directly or indirectly from the use of this quick guide.

©All rights reserved. Vaillant, 2023.

Hint:

Follow the symbol to dedicated documents for more detailed information.



Hint:

Scan the QR code to download the digital version of this Quick Guide.





Get started quickly!

Your perfect installation with aroTHERM pure step-by-step:

Plan your Work ...	
» Select the ideal aroTHERM pure to fit your needs: performance, dimensions, sound	4
» Find the perfect space for your installation: quiet, vented	7
» Select the perfect domestic hot water and buffer storage	13
» Dimension the expansion vessel	14
» Select your system scheme (system components, hydraulics and wiring)	15
» Decide on installation type	16
» Select refrigerant pipes	17
» Tick your planning checklist <input checked="" type="checkbox"/>	18
... work your Plan: Install the aroTHERM pure system	
» Realize the condensate drain	21
» Install the refrigerant pipes	22
» Proceed to the power supply and Modbus connection	24
» Connect the uniTOWER pure or hydraulic module	26
» Commission the refrigerant circuit	29
» Tick your installation checklist <input checked="" type="checkbox"/>	30
... and start your System	
» Follow the instructions of the installation assistant	31
» Just in case: Find remedies to error, status and maintenance codes	31
Find technical data...	
» aroTHERM pure	32
» uniTOWER pure, hydraulic module	33

Check the product installation manuals for further information.

We are here to help you!

Don't hesitate to contact us for further support:

Vaillant GmbH

Berghauser Str. 40 ■ D-42859 Remscheid
Tel. +492191 18 0 ■ Fax +492191 18 2810
info@vaillant.de ■ www.vaillant.de



Plan your work ...

Select the ideal aroTHERM pure to fit your needs

Heating output *

---●--- VWL 45/7.2 AS —●— VWL 85/7.2 AS
—●— VWL 65/7.2 AS -.-.-●-.-.- VWL 105/7.2 AS

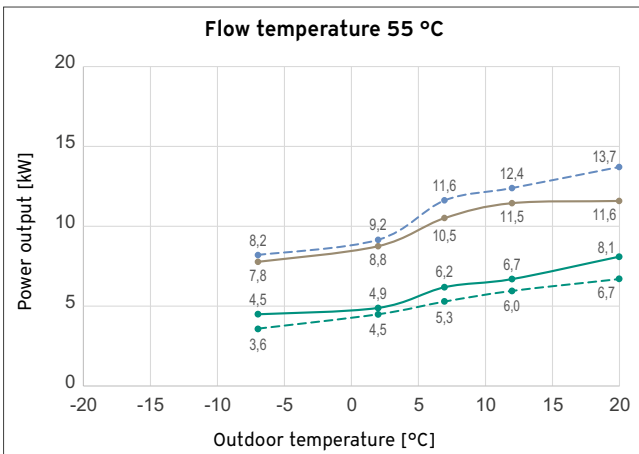
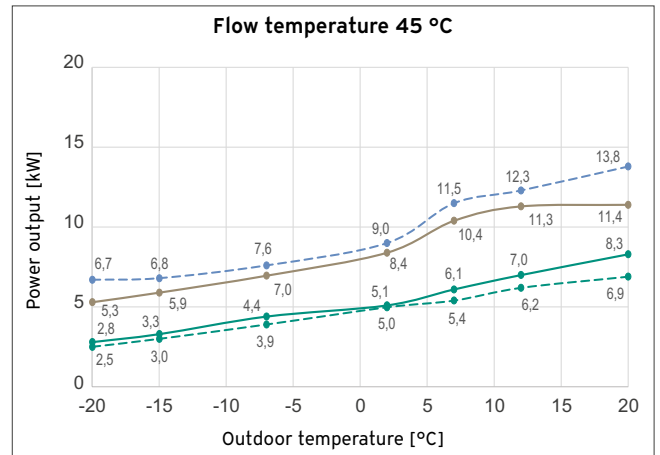
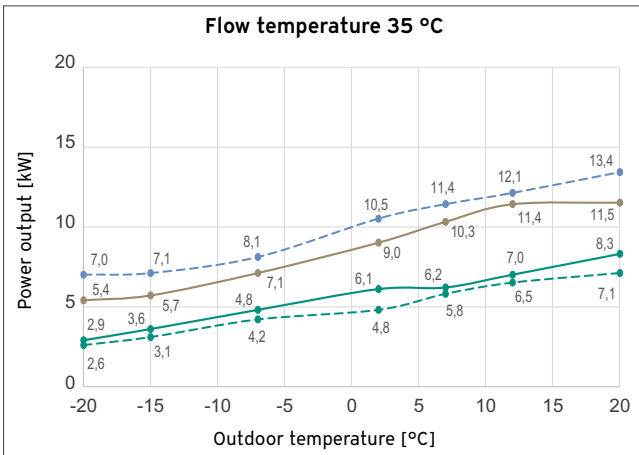

Cooling output *

---●--- VWL 45/7.2 AS —●— VWL 85/7.2 AS
—●— VWL 65/7.2 AS -.-.-●-.-.- VWL 105/7.2 AS

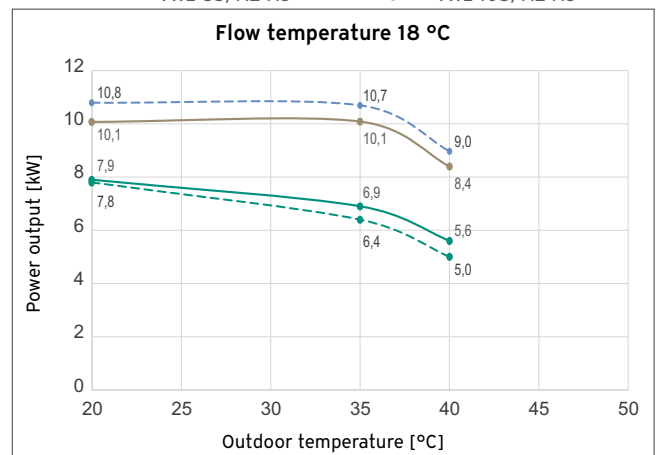
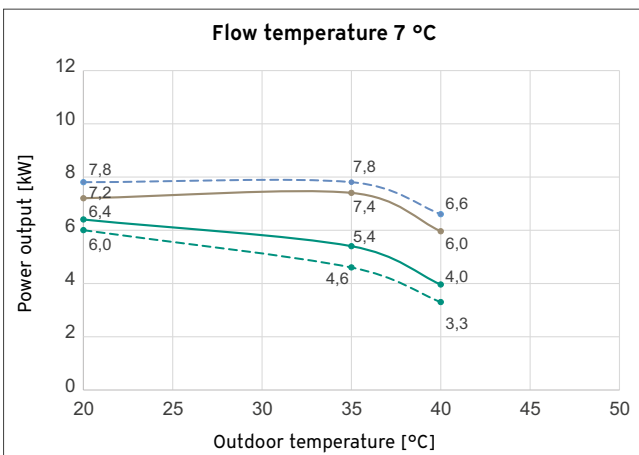

* at maximum compressor speed



Product dimensions

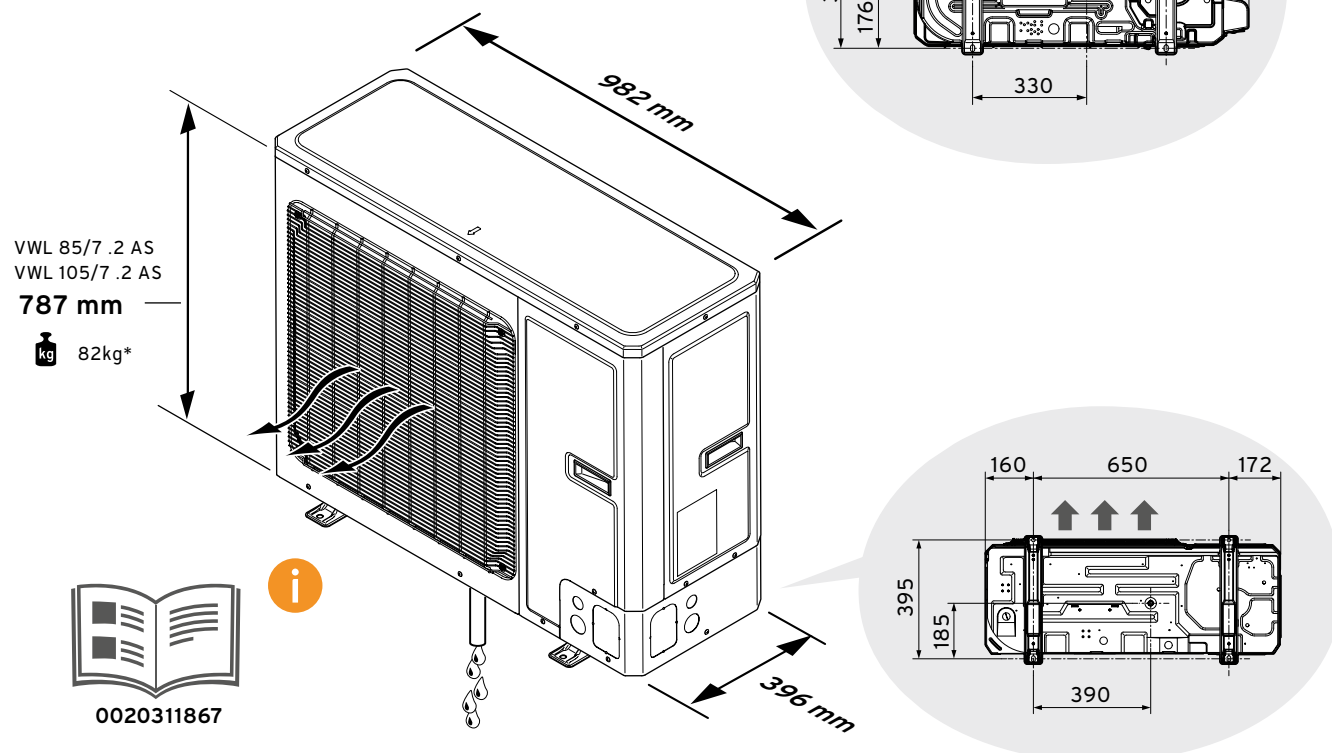
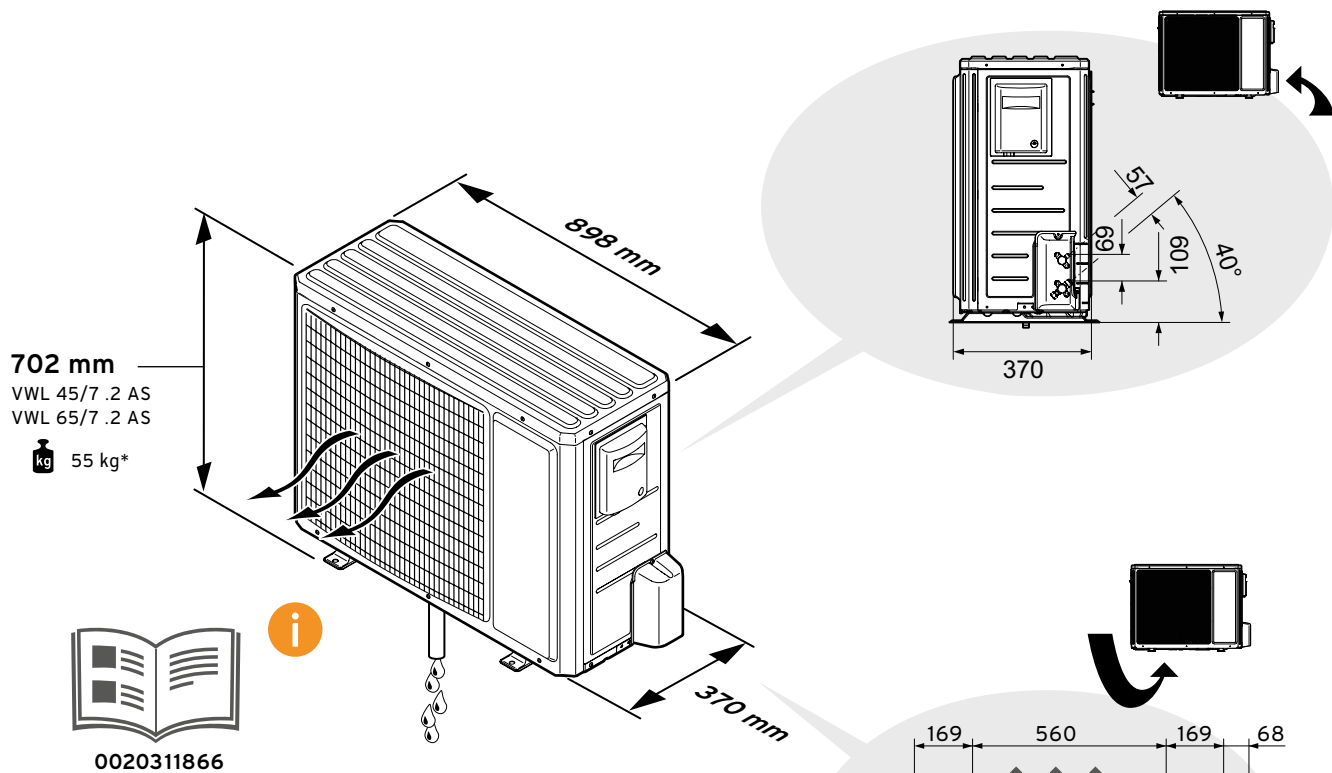

*unboxed, ready for operation



Sound pressure level

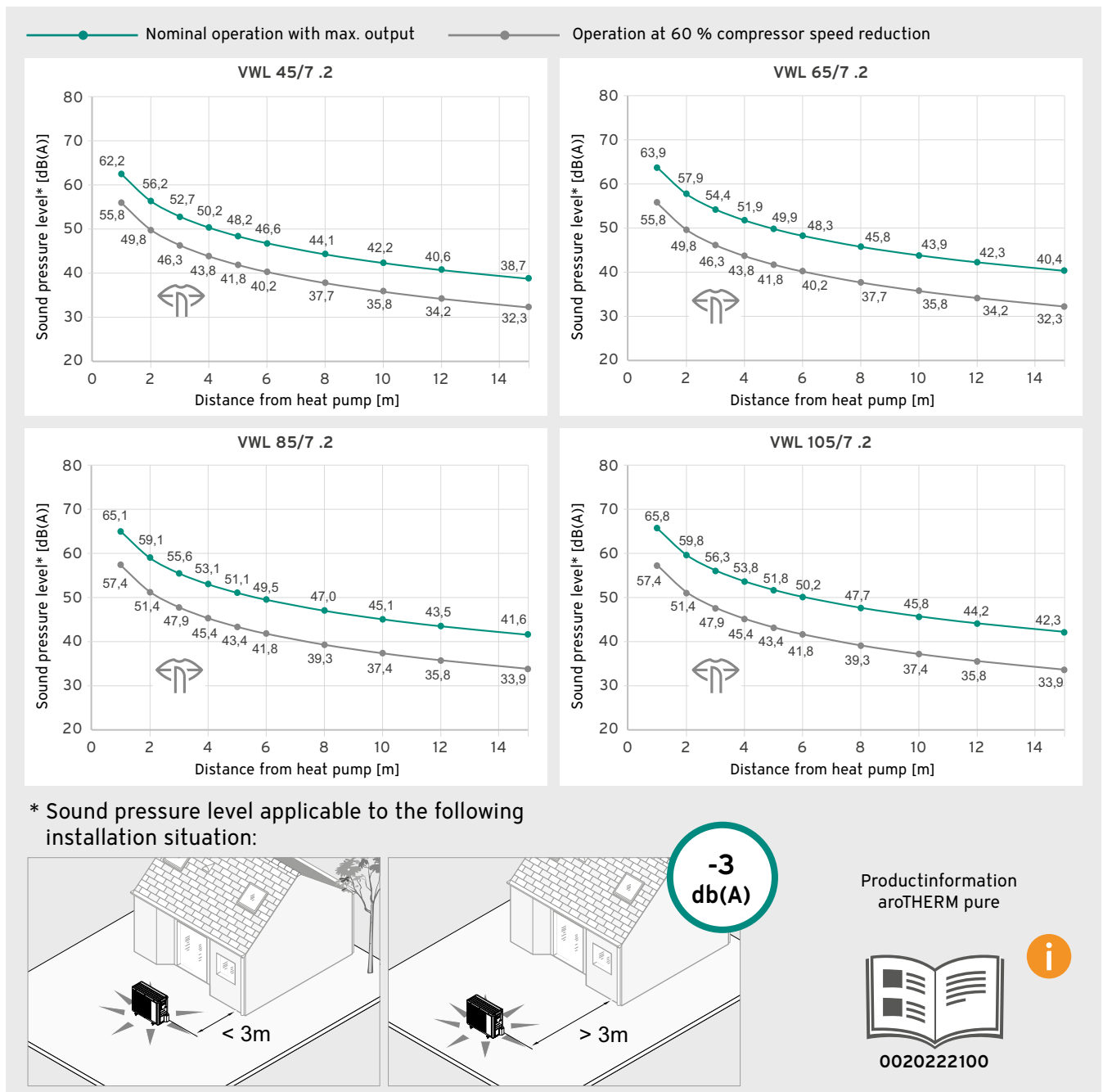

The sound pressure level increases by 3 db(A) in the following installation situations:

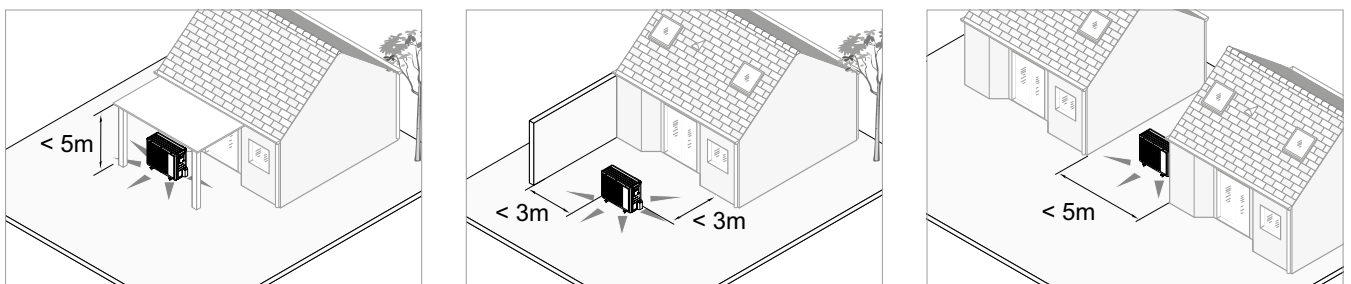



Find the perfect space for your installation

A quiet space for your installation

Do! 

Don't 

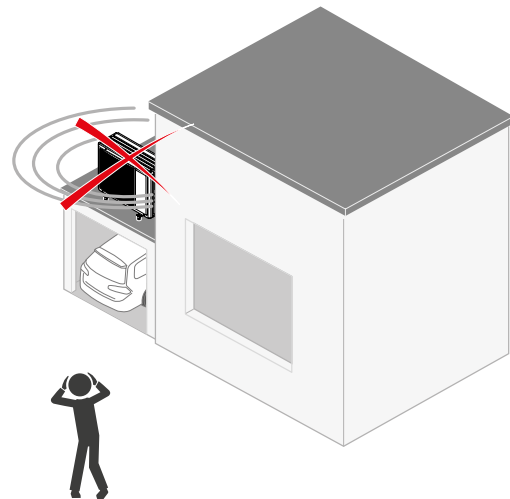
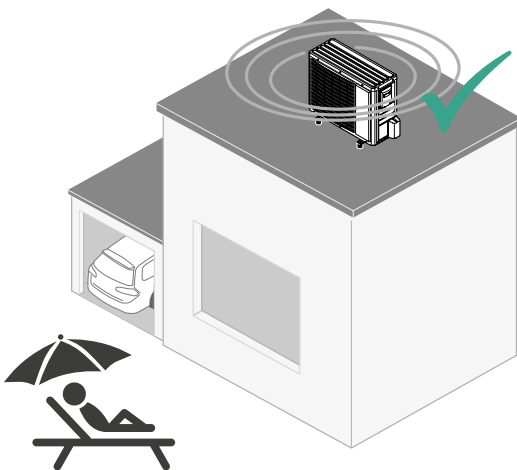
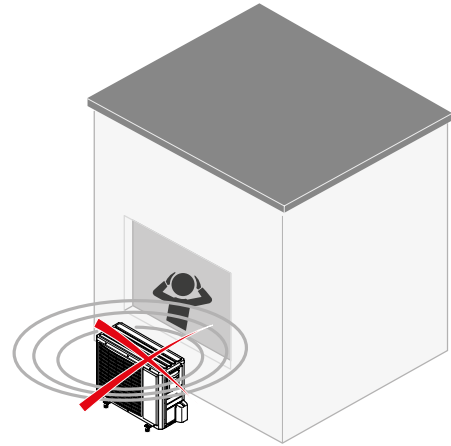
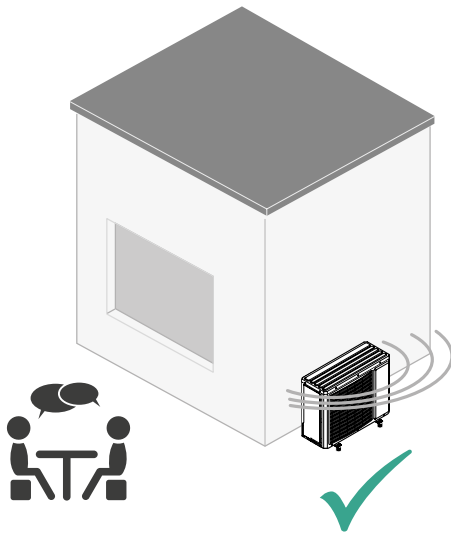



Calculate the minimum room size for indoor unit installation

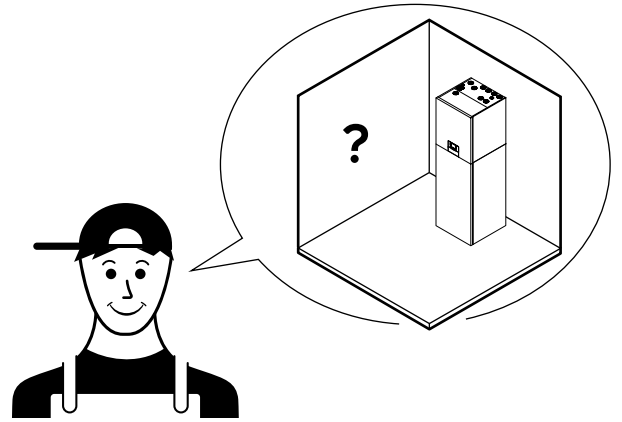
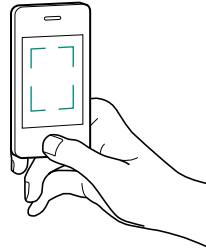
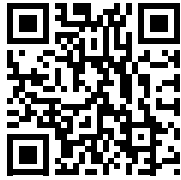

Scan the QR code to easily determine the required room volume

A vented space for perfect operation

Do!

Don't

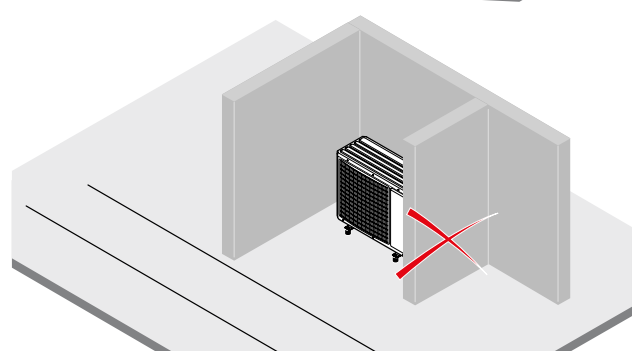
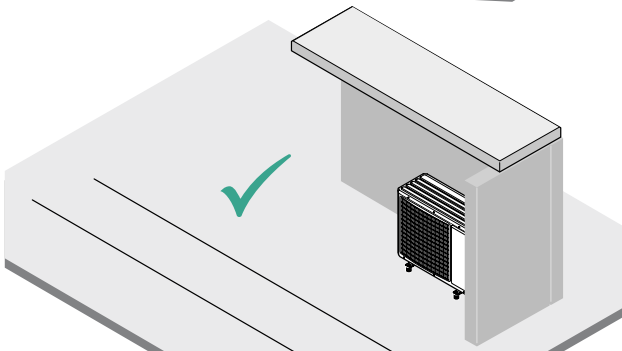
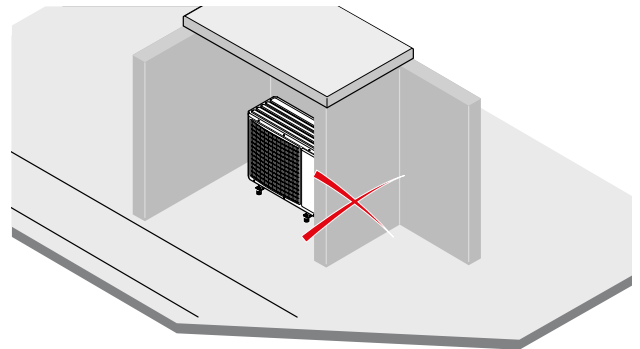
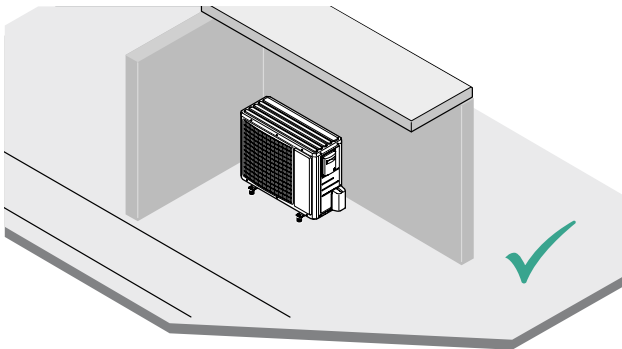



Minimum distances for flawless operation

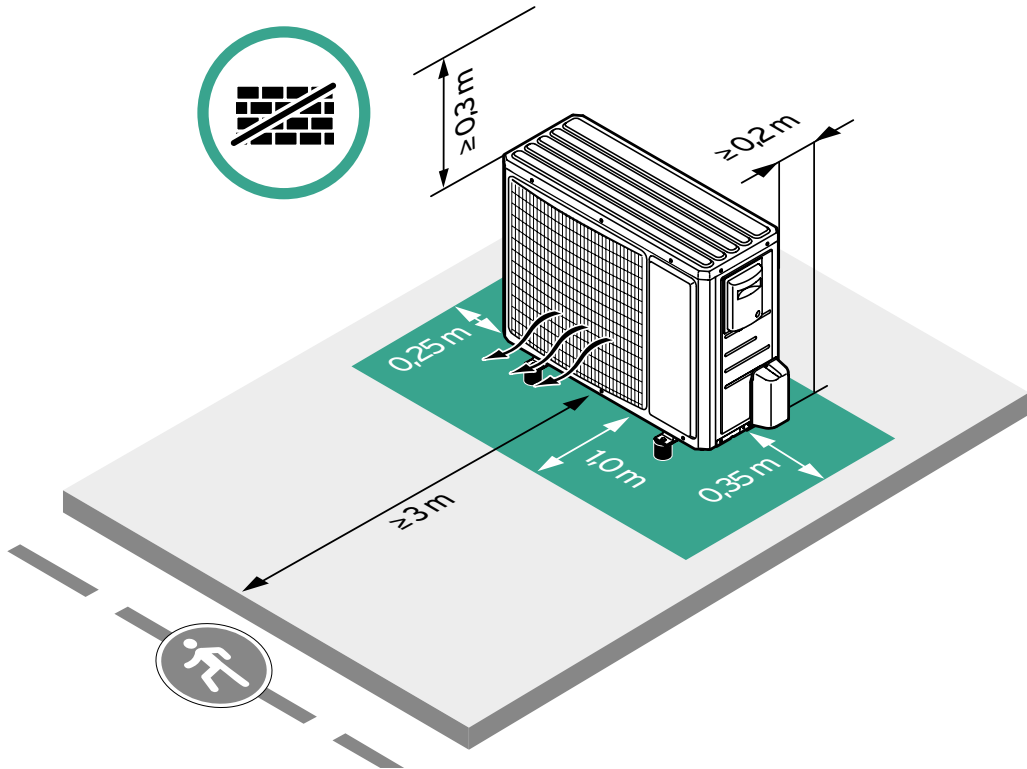

Install several aroTHERM pure in one spot

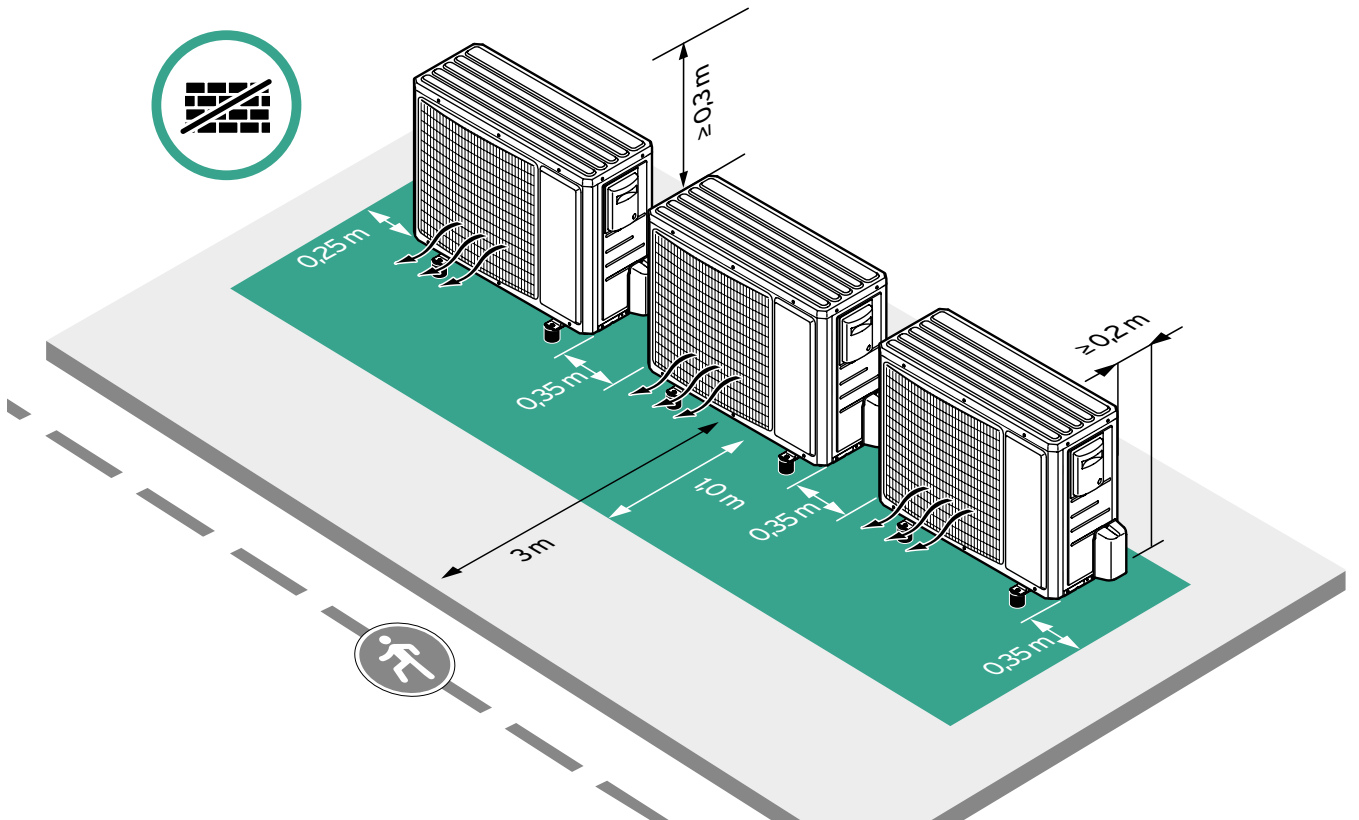



Install several aroTHERM pure in one spot

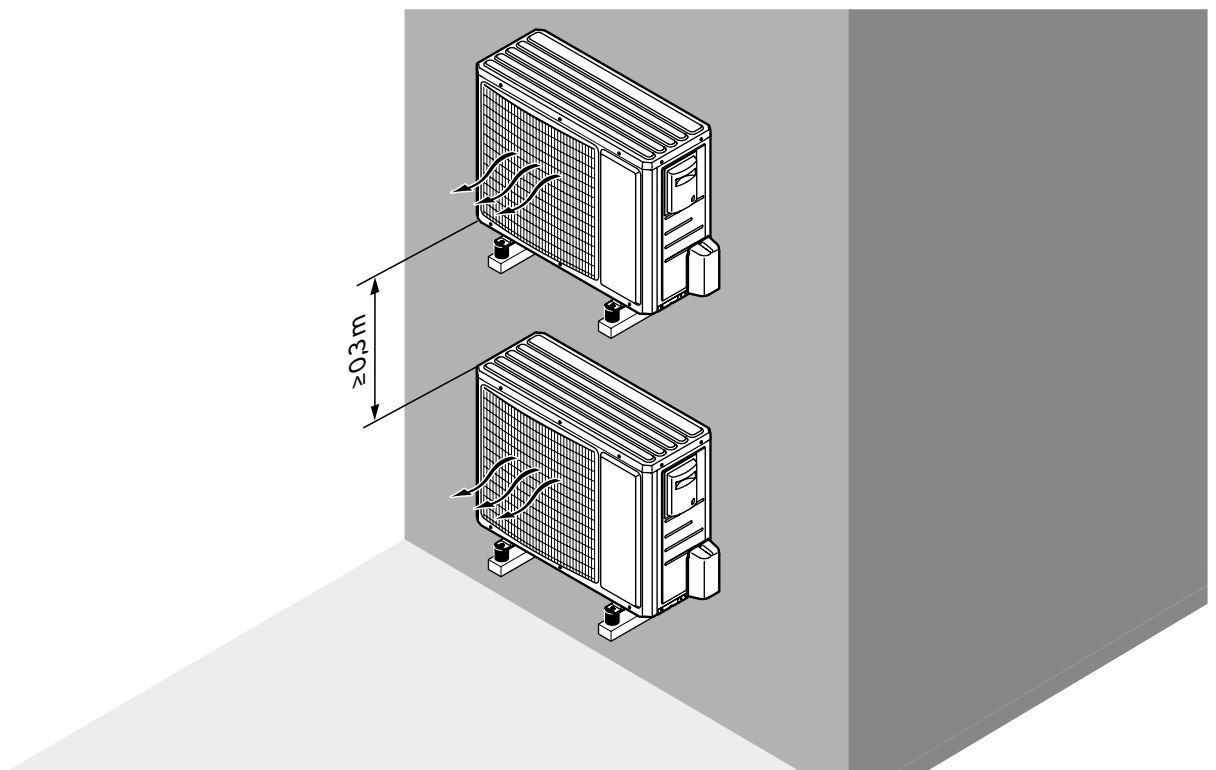
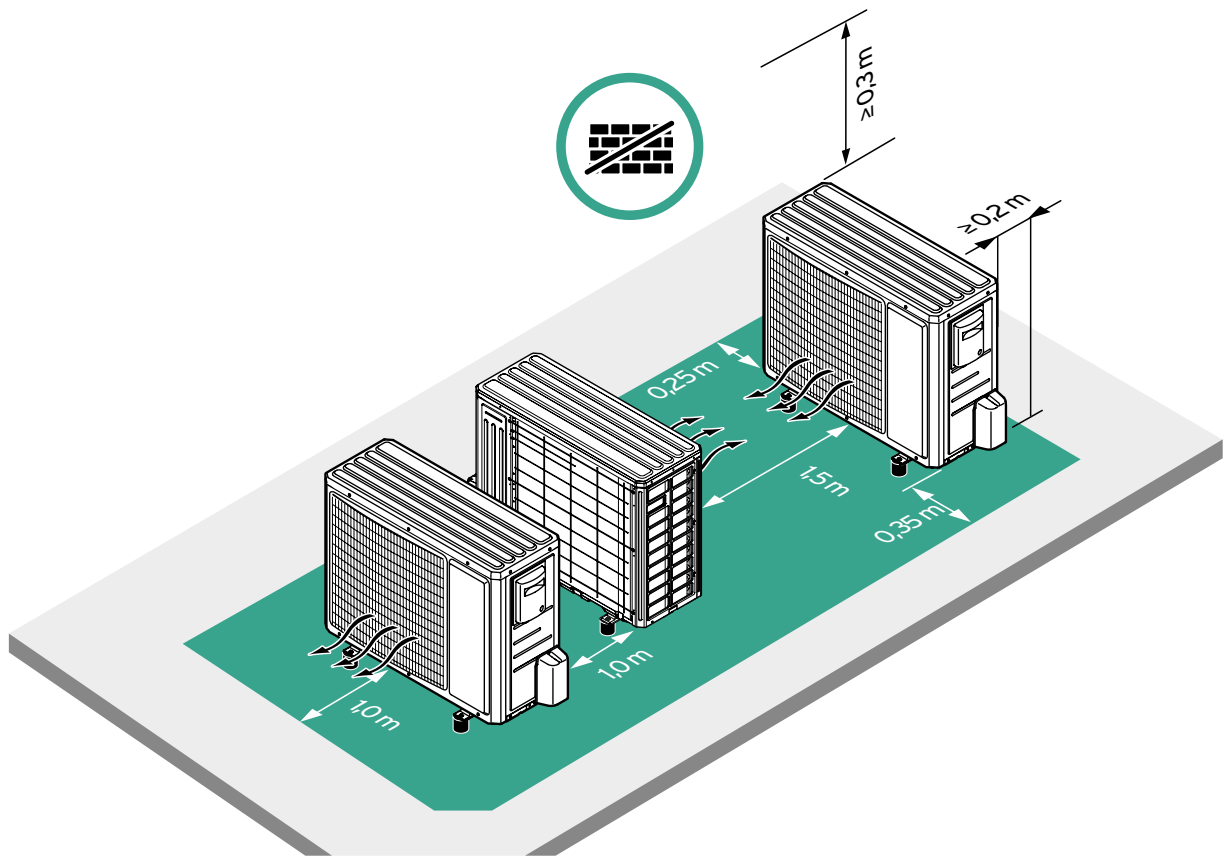



Install several aroTHERM pure in one spot

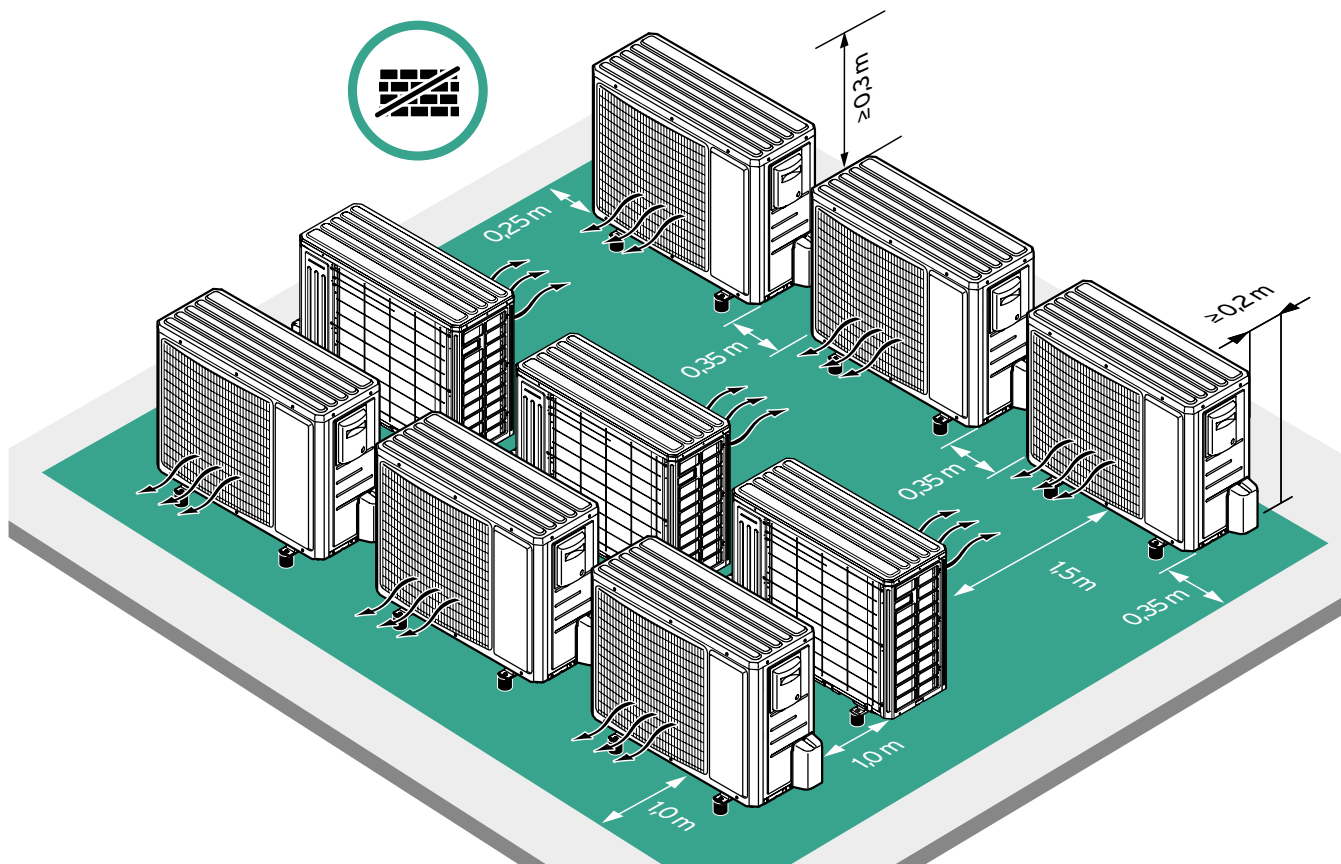

Plan the foundation

VWL 45/7 .2 AS, VWL 65/7 .2 AS

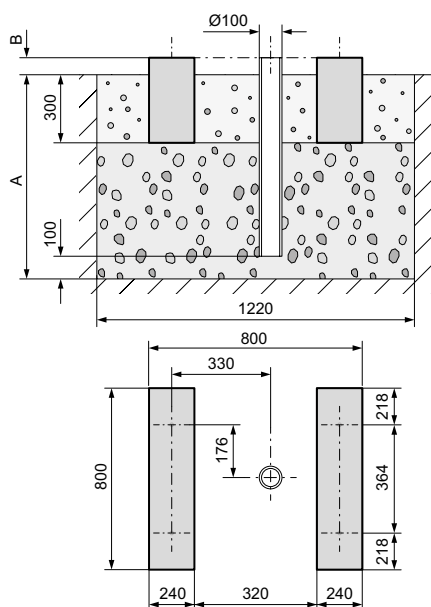

VWL 85/7 .2 AS, VWL 105/7 .2 AS

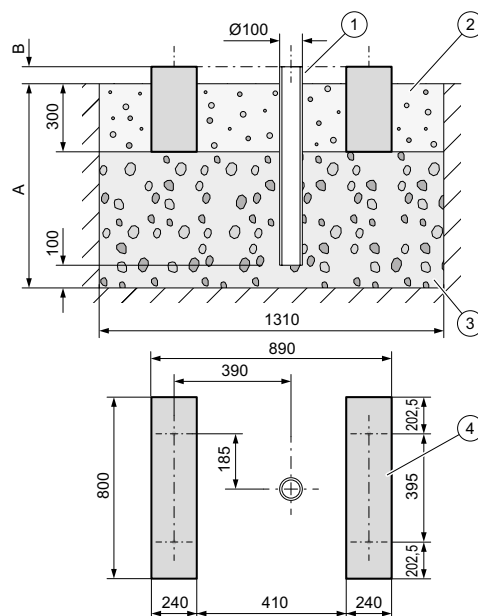

Rear of the heat pump



Front of the heat pump

	A	B
Region with ground frost	> 900 mm	In accordance with local conditions
Region without ground frost	> 600 mm	

- 1 Downpipe
- 2 Gravel bed
- 3 Coarse rubble
- 4 Concrete strip foundation



Maximum height difference between indoor and outdoor unit

Outdoor unit above indoor unit

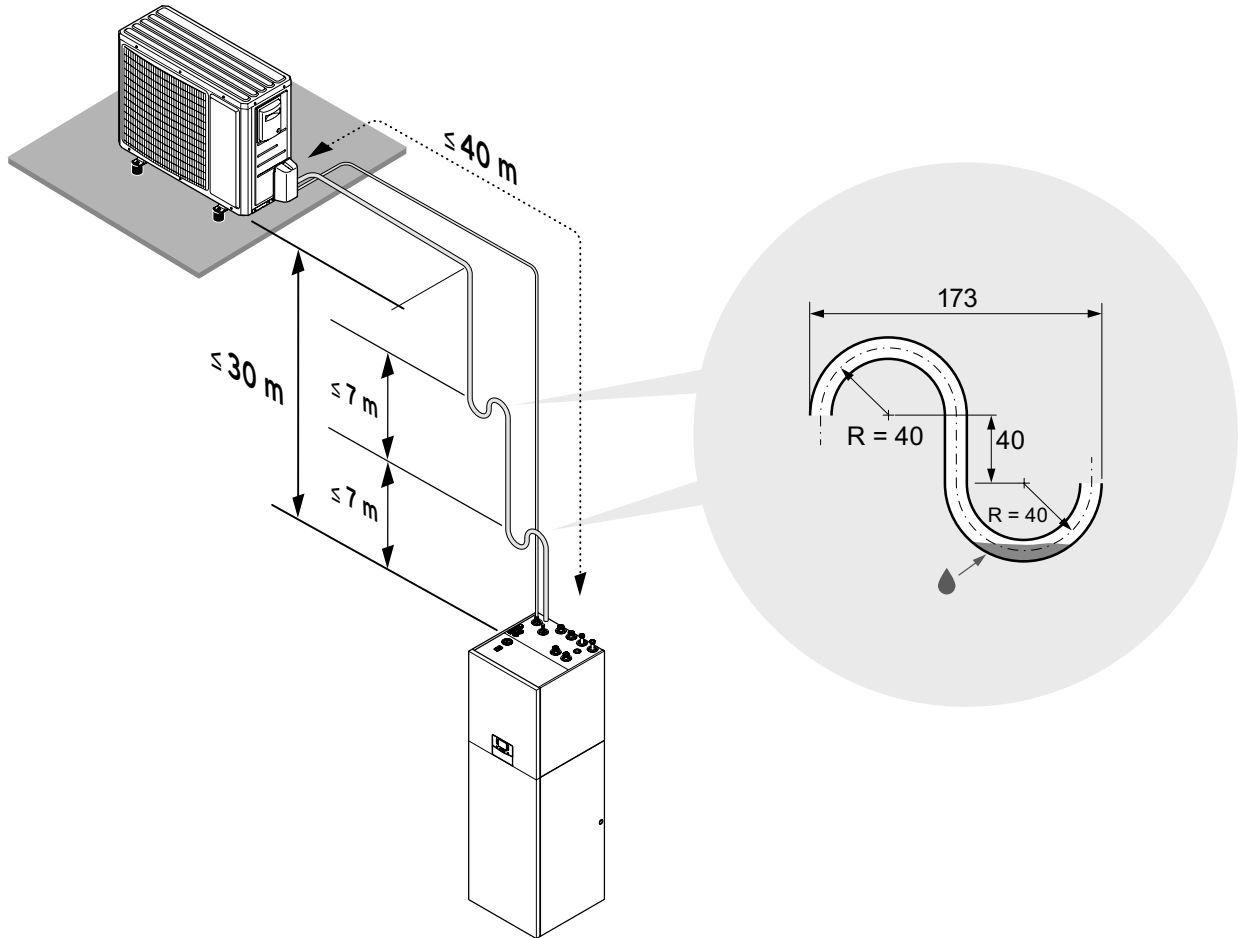

Outdoor unit below indoor unit

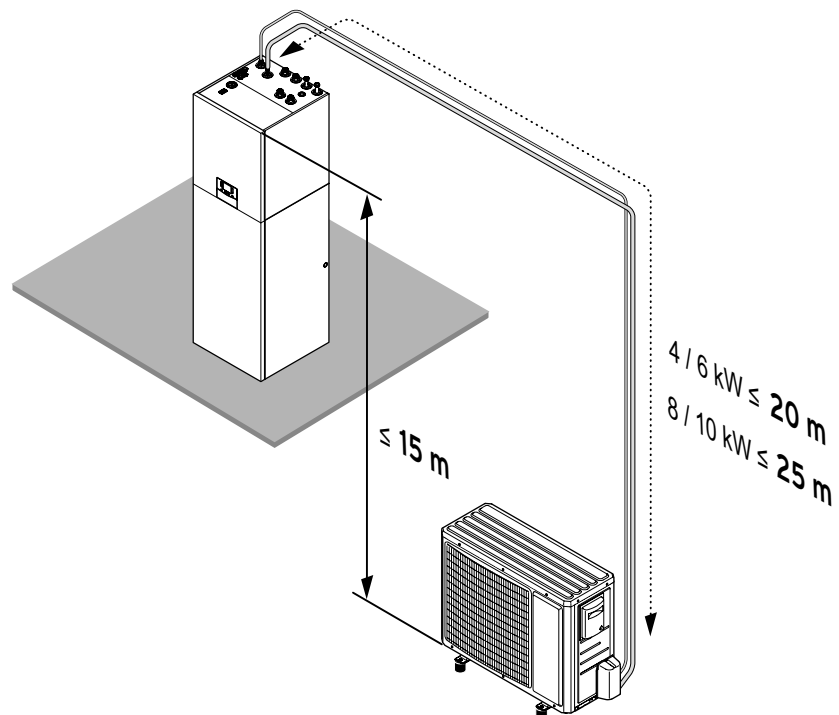



Select the perfect domestic hot water and buffer storage

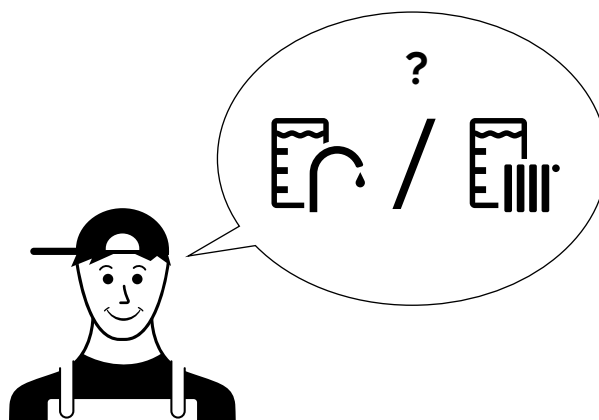
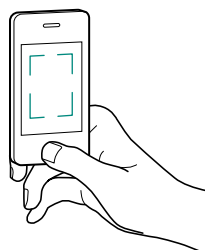

Scan the QR code to quickly calculate the required storage volume

Storage heated up by heat pump only					... heat pump and solar heat	
Storage	uniTOWER pure VWL IS	uniSTOR VIH RW 200	uniSTOR VIH RW 300	uniSTOR VIH RW 400	uniSTOR VIH RW 500	uniSTOR VIH SW 400	uniSTOR VIH SW 500
Capacity heated up by the heat pump	188 l	200 l	300 l	400 l	500 l	200 l	250 l
Tap capacity with 38 °C at 55 °C inside the storage	302 l	321 l	482 l	643 l	804 l	321 l	402 l
aroTHERM pure	Time to reheat storage to 55°C without backup heater, once temperature falls below 46°C at 7°C outdoor temperature						
VWL 45/7 .2 AS	31 min	33 min	49 min	65 min*	81 min*	33 min	41 min*
VWL 65/7 .2 AS	22 min	23 min	35 min	46 min*	58 min*	23 min	29 min*
VWL 85/7 .2 AS	20 min	21 min	32 min	42 min	52 min*	21 min	26 min
VWL 105/7 .2 AS	18 min	19 min	29 min	38 min	47 min	19 min	24 min

* conditionally recommended: longer heating times can lead to limited comfort



Minimum required buffer/ water volume for deicing

aroTHERM pure	With activated and not limited electric backup heater	With limited or non-activated electric backup heater
VWL 45/7 .2 AS	0 l	40 l *
VWL 65/7 .2 AS	0 l	40 l *
VWL 85/7 .2 AS	0 l	80 l *
VWL 105/7 .2 AS	0 l	80 l *

* The volume can be ensured by using a buffer storage tank

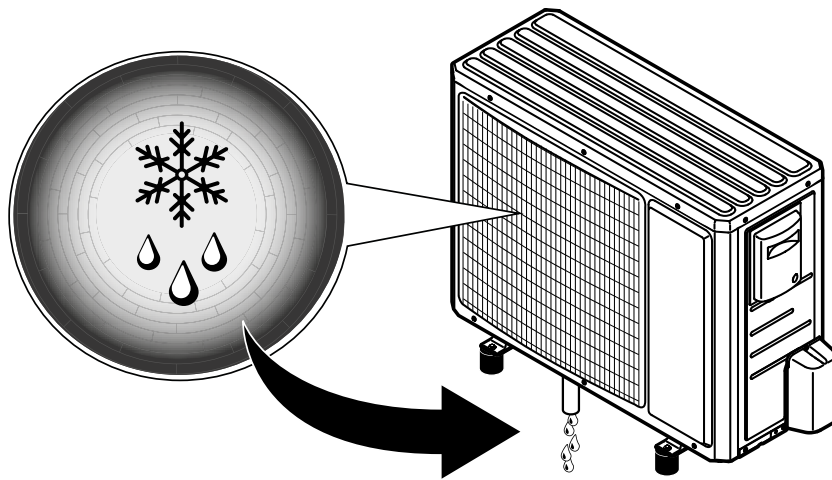

Dimension the expansion vessel

Scan the QR code to easily dimension your expansion vessel

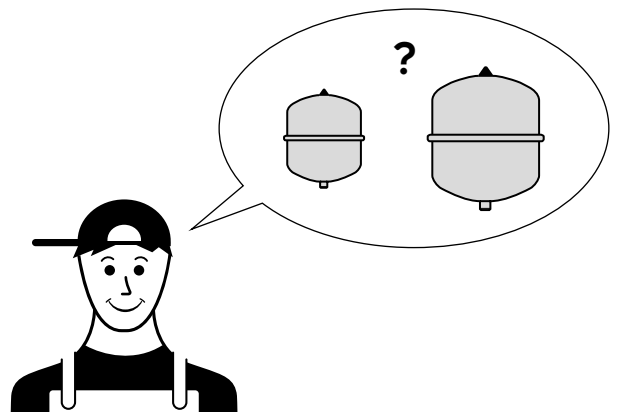
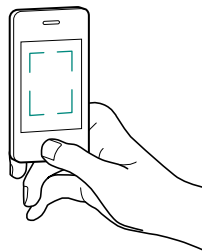

Scan or Click QR-Code for dimensions of the expansion vessel



Remaining pressure head of heating circuit pump

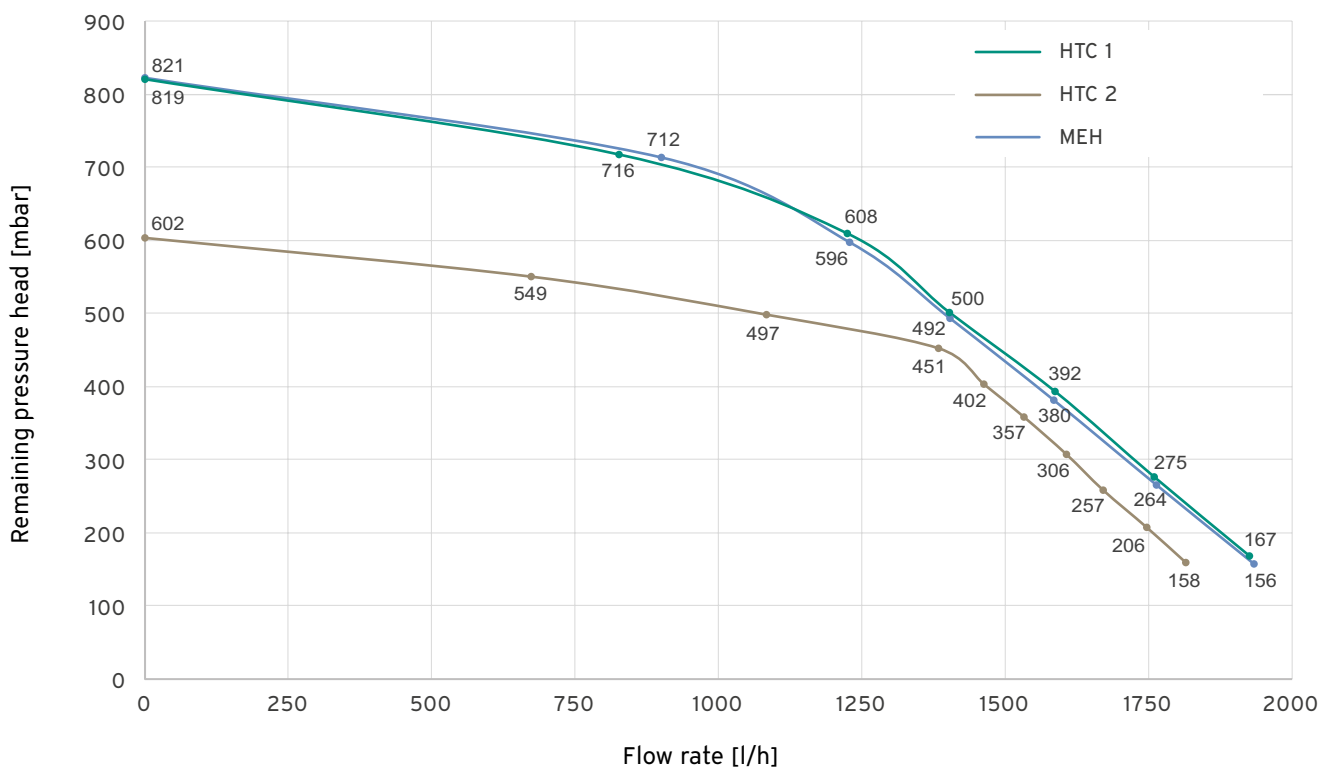

Select your system scheme (system components, hydraulics and wiring)

Scan the QR code to select a system scheme from our broad data base

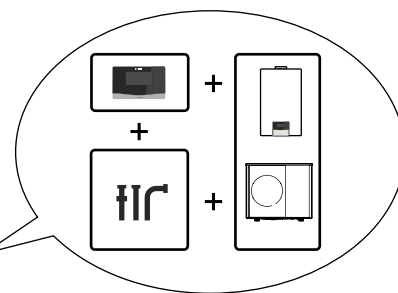
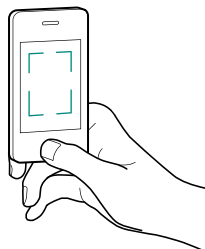

Scan or Click QR-Code to select system scheme



Decide on the installation type

On the roof ...

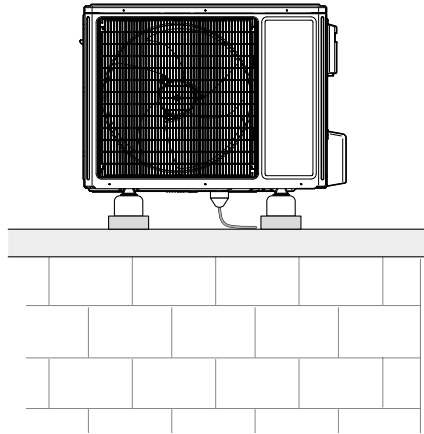

On the wall ...

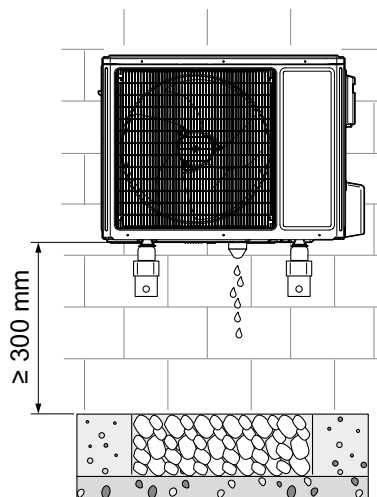

On the ground ...

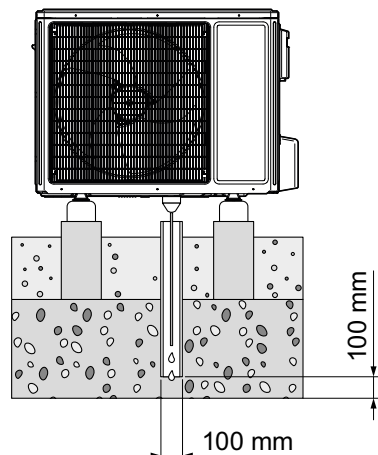



Note:
It is recommended to
use damping feet with
a width of min. 60 mm





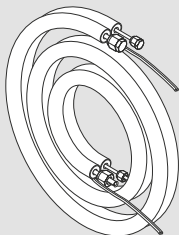

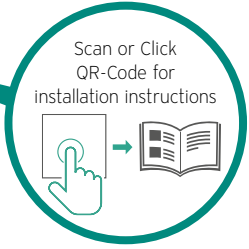



Select refrigerant pipes

aroTHERM pure	Connection type and Installation accessories		
	Distance between outdoor unit and indoor unit		
	up to 5 m	5 m to 10 m	up to 25 m
VWL 45/7 .2 AS VWL 65/7 .2 AS VWL 85/7 .2 AS VWL 105/7 .2 AS	Twin tubes, 5 m (1/4" + 1/2") Art.-No: 0020250307	Twin tubes, 10 m (1/4" + 1/2") Art.-No: 0020250308	Refrigerant pipe, 25 m (1/4") Art.-No: 0020250311 + Refrigerant pipe, 25 m (1/2") Art.-No: 0020250312
			
	Note: The enclosed cable cannot be used for the modBUS communication.		
			

Accessories for fitting the refrigerant lines

Figure	Description	Art.-No.
Insulating tape		
	Insulating tape Self-adhesive for the refrigerant pipe	0020252090
SAE connector set		
	SAE screw-type connector 1/4" (1 Pcs)	0010030970
	SAE screw-type connector 1/2" (1 Pcs)	0010030972
	SAE screw-type connector 1/4" (10 Pcs)	0020252878
	SAE screw-type connector 1/2" (10 Pcs)	0020252880
	SAE calibration set 1/4", 1/2", 3/8", 5/8" Is required in order to establish the SAE connection	0020252903

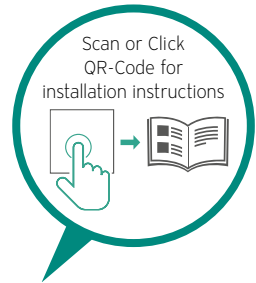

Select accessories for the uniTOWER pure (C2) or the hydraulic module

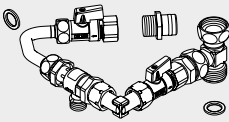

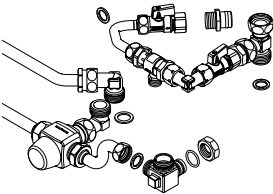

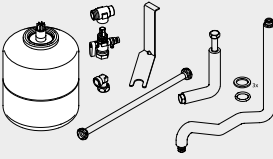

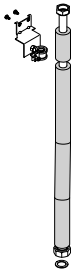

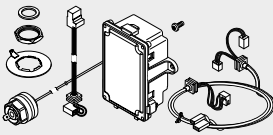







Figure	Description	Art.-No.	uniTOWER pure			Hydraulic module pure	
			108/7.2 IS	108/7.2 IS S5	108/7.2 IS C2	107/7.2 IS	107 /7.2 IS S1
	Refilling the heating circuit Connected to domestic hot water and heating return Incl. partition and two valves with handle	0010038388 	•		•		
	Refilling the heating circuit Connected to domestic hot water and heating return Checking the maximum outlet temperature	0010038386 	•		•		
	Potable water expansion vessel installation kit 8-litre potable water expansion vessel (flow-through), 3/4" connection fittings, G 3/4" flexible connection pipes	0010038391 	•	•			
	Circulation set without pump Connection pipe with G 3/4" coupling, pipe set for circulation connection for connecting to a circulation pump that is available on-site	0010042664 	•	•	•		
	Universal external current anode with connection accessories M8 external current anode with 3/4" adapter, power supply unit, cable, small parts for replacing the magnesium protection anode that is already available on-site	0020170505 	•	•	•		



Figure	Description	Art.-No.	uniTOWER pure			Hydraulic module pure	
			108/7.2 IS	108/7.2 IS S5	108/7.2 IS C2	107/7.2 IS	107 /7.2 IS S1
	<p>Uninsulated installation set for installing the hydraulic tower in rooms with a low ceiling height of 2.1 m. The connection to the home installation takes place on the right-hand side. It is not possible to use the internal buffer module. Increase in installation depth + 10 cm!</p>	0010039993 	•	•	•		
	<p>7 bar potable water expansion relief valve</p>	0010040739 	•		•		
	<p>Set with two pieces - 1" flat-sealing outside thread on 28 mm copper pipe for pressing or soldering</p>	0010038385	•		(2x)	(2x)	
	<p>Two-piece set - 1" flat-sealing outside thread on 28 mm copper pipe for pressing or soldering</p>	0010039178		•		(1x)	(2x)
	<p>DN 25 bypass valve Required for air-to-water heat pump installations in order to guarantee the min. volume flow 0 - 350 mbar</p>	0010039715	•	•	•	•	•

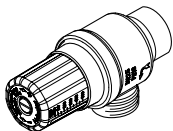

Check your plan!

Tick your planning checklist

<input type="checkbox"/>	Heat pump depending on the heating and cooling load calculation chosen
<input type="checkbox"/>	Installation site of the outdoor unit planned (quiet, vented)
<input type="checkbox"/>	Installation site of the indoor unit planned (minimum room size)
<input type="checkbox"/>	Construction of the foundation planned (for ground installation)
<input type="checkbox"/>	System temperatures chosen (underfloor, radiator, fan coil)
<input type="checkbox"/>	Domestic hot water and buffer tank chosen
<input type="checkbox"/>	Expansion vessel determined
<input type="checkbox"/>	System scheme selected
<input type="checkbox"/>	System components incl. accessories for installation ordered



... work your Plan

Install the aroTHERM pure system.

Realize the condensate drain

Note:

In regions with ground frost:
Do not install a condensate discharge tundish and a plug in the floor plate.



Do!

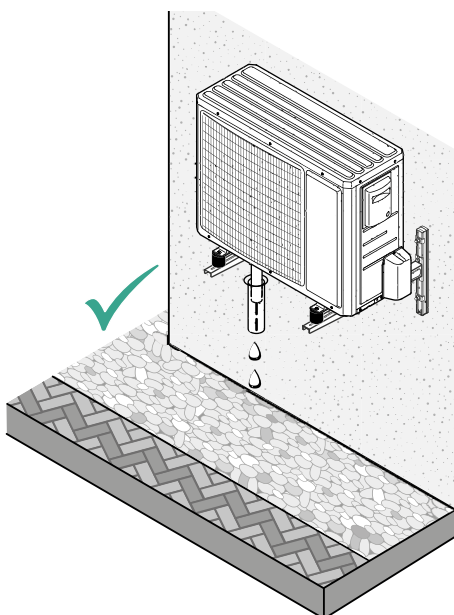
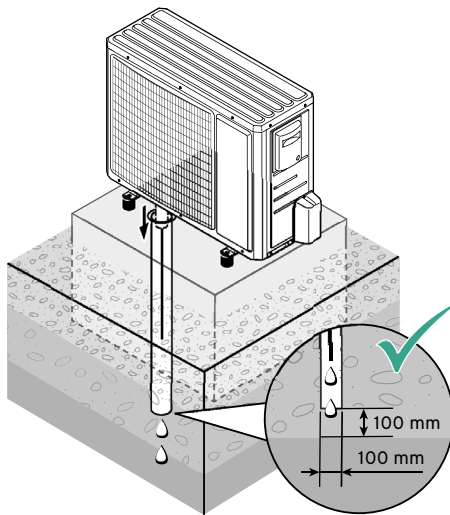

Don't

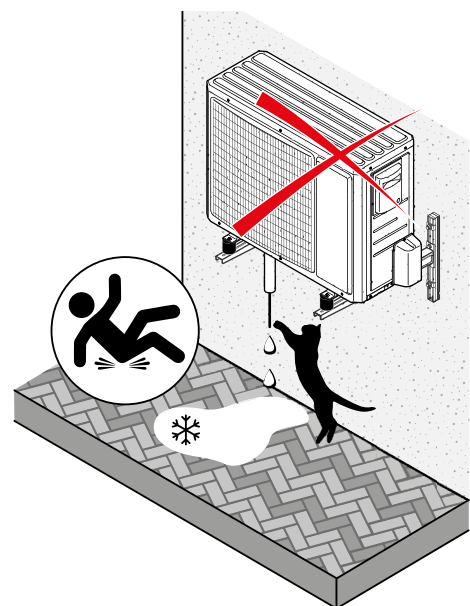
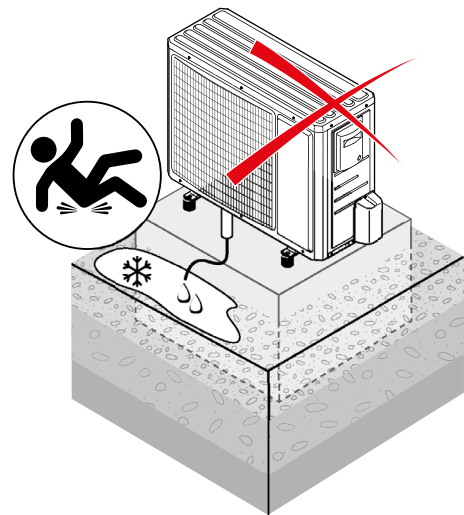



Install the refrigerant pipes

Realize the quietest installation

Origin of vibrations

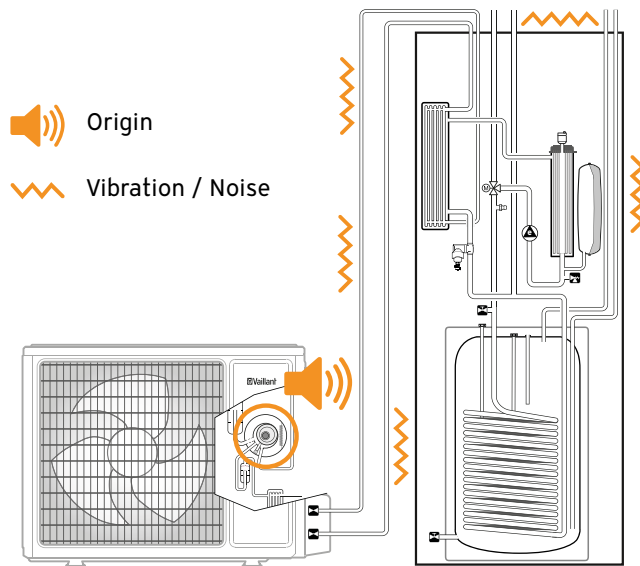

Avoid kinks in the pipe

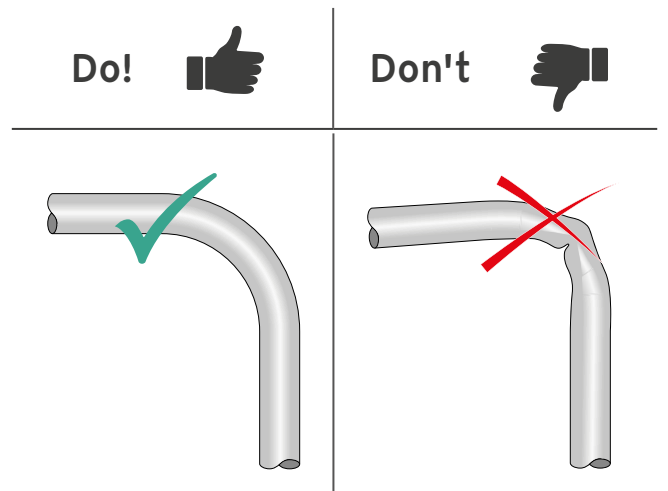

How to minimize vibrations

Fix refrigerant pipes with appropriate refrigerant clamps.

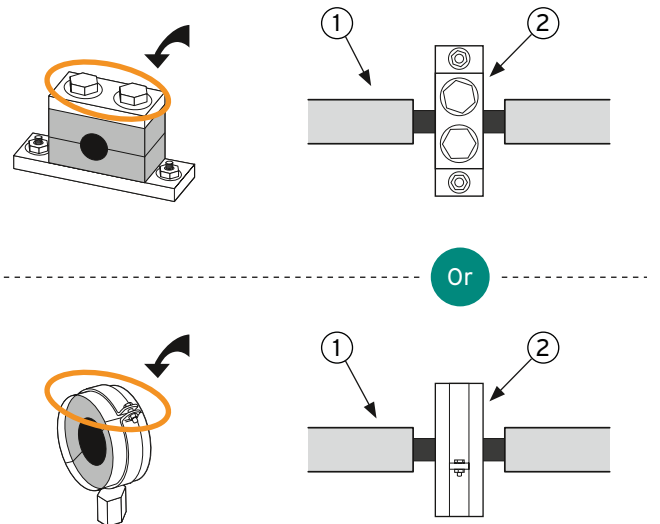
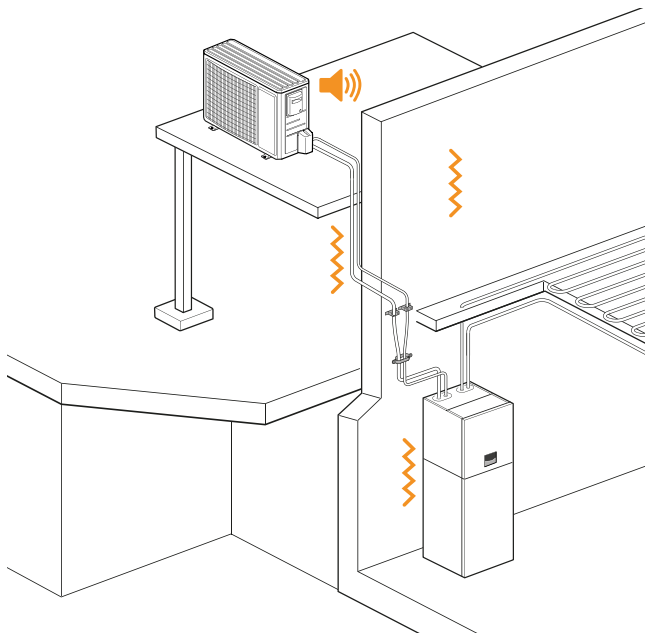

- 1 | Pipe with insulation
- 2 | Refrigerant clamp



Connect the refrigerant pipes

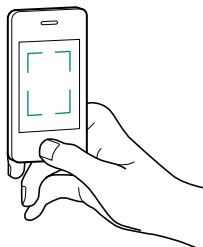

Scan or Click QR-Code for installation video

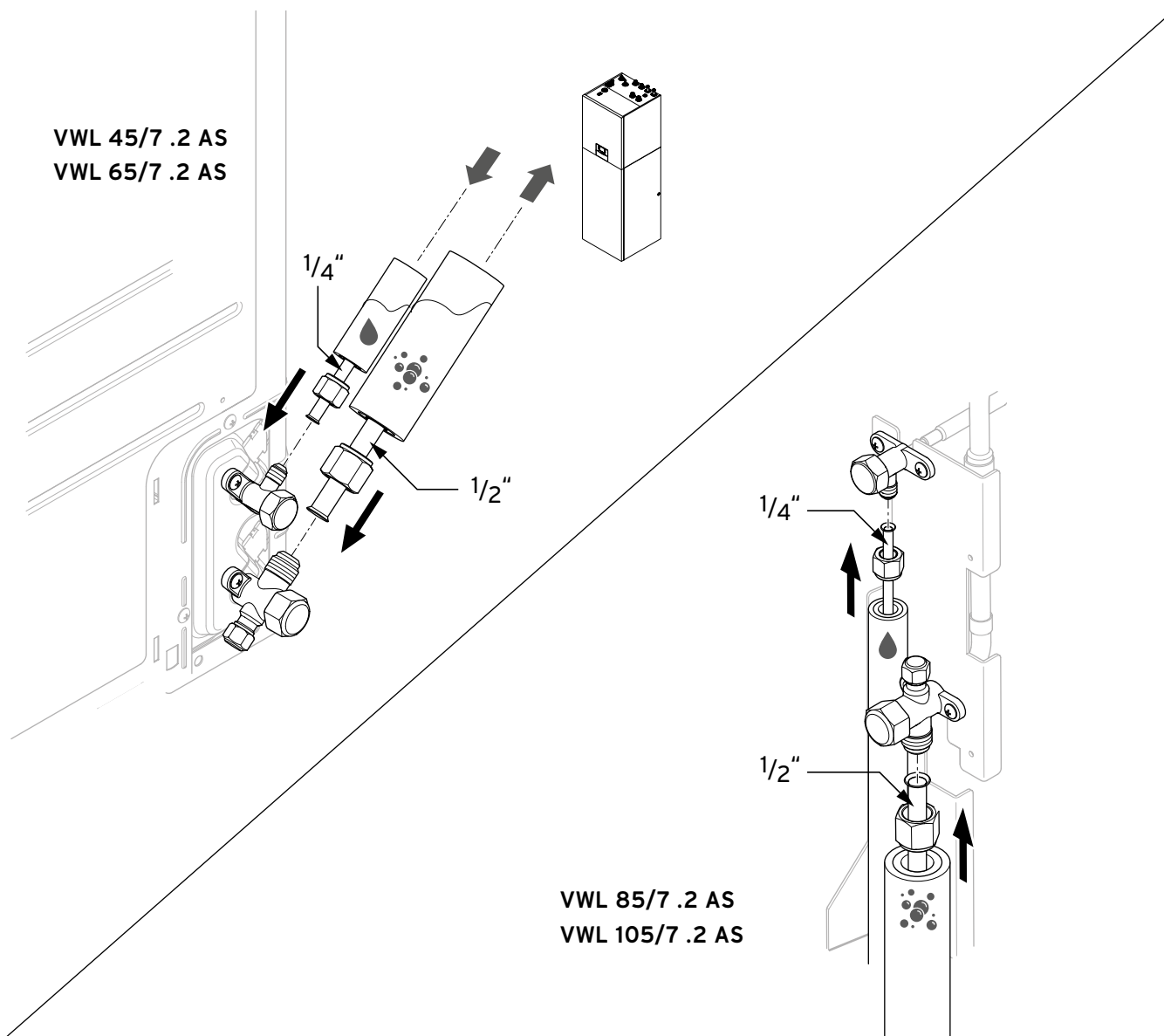



Proceed to the power supply and Modbus connection

Calculate the cable cross section

Scan the QR-Code to easily calculate the required cable cross section for the wiring

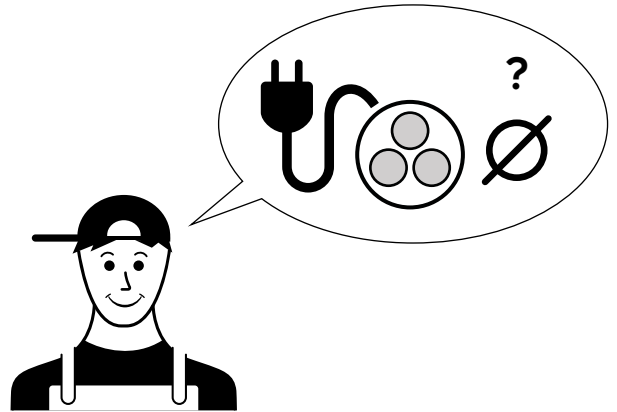
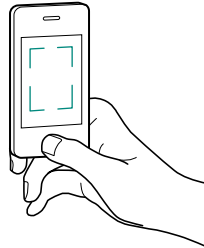

Scan or Click QR-Code for calculating the cable cross section

Preparation

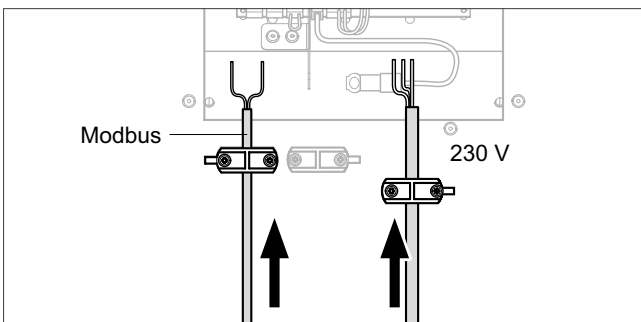
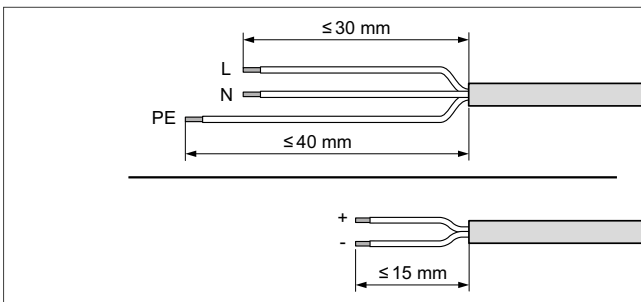

Power supply connection (230 V)

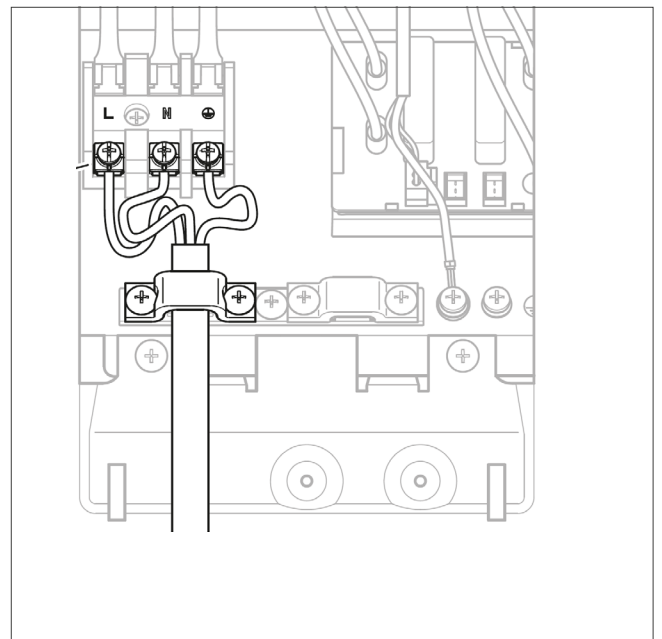

Electrical connections

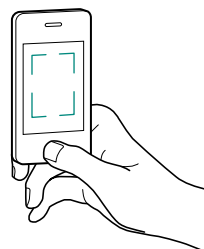

Scan or Click QR-Code for installation video



Modbus connection

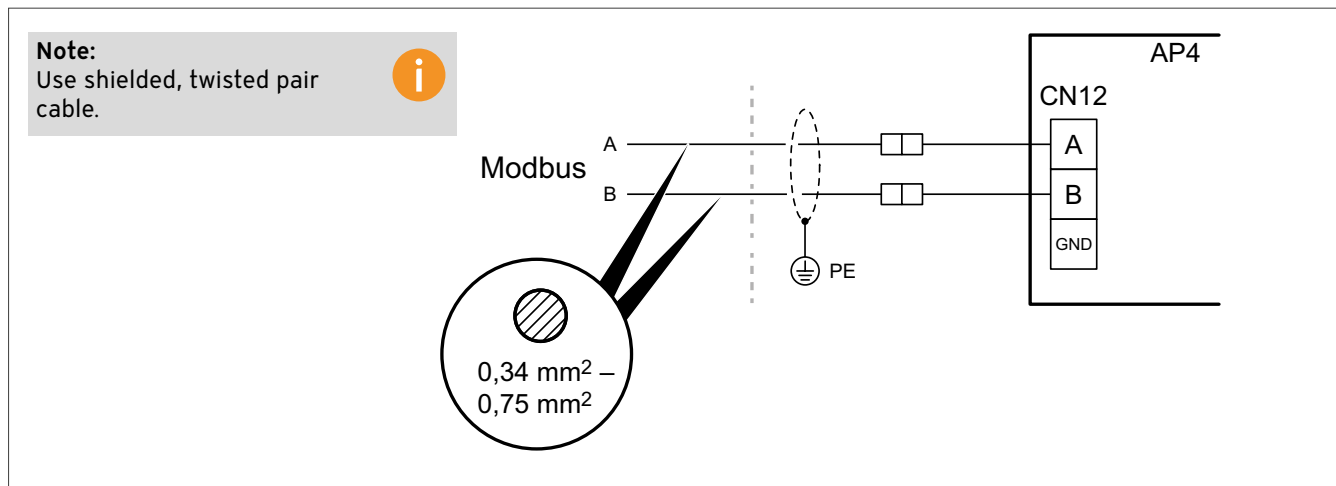

up to 15 m cable length

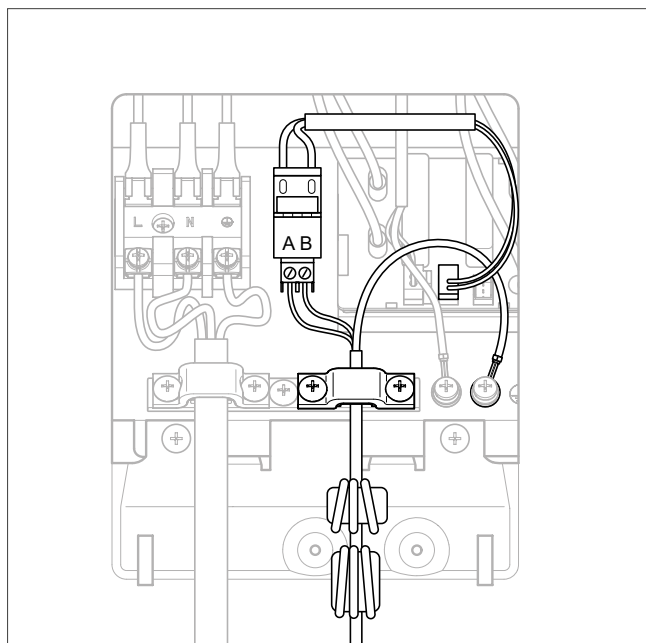

over 15 m cable length

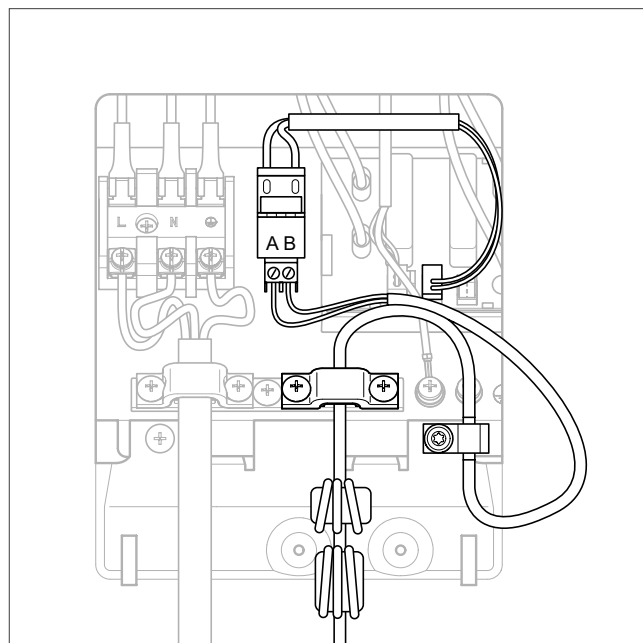

Modbus cable as an accessory

Figure	Description	Art.-No.
	Modbus cable for connecting the outdoor unit to the indoor unit 50 m, 2 x 0.34 mm ² twisted pair, shielded	0010039719



Connect the uniTOWER pure or hydraulic module

Install the uniTOWER pure VWL 108/7.2 IS or VWL 108/7.2 S5

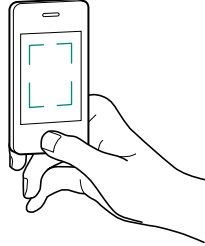

Scan or Click QR-Code for installation video

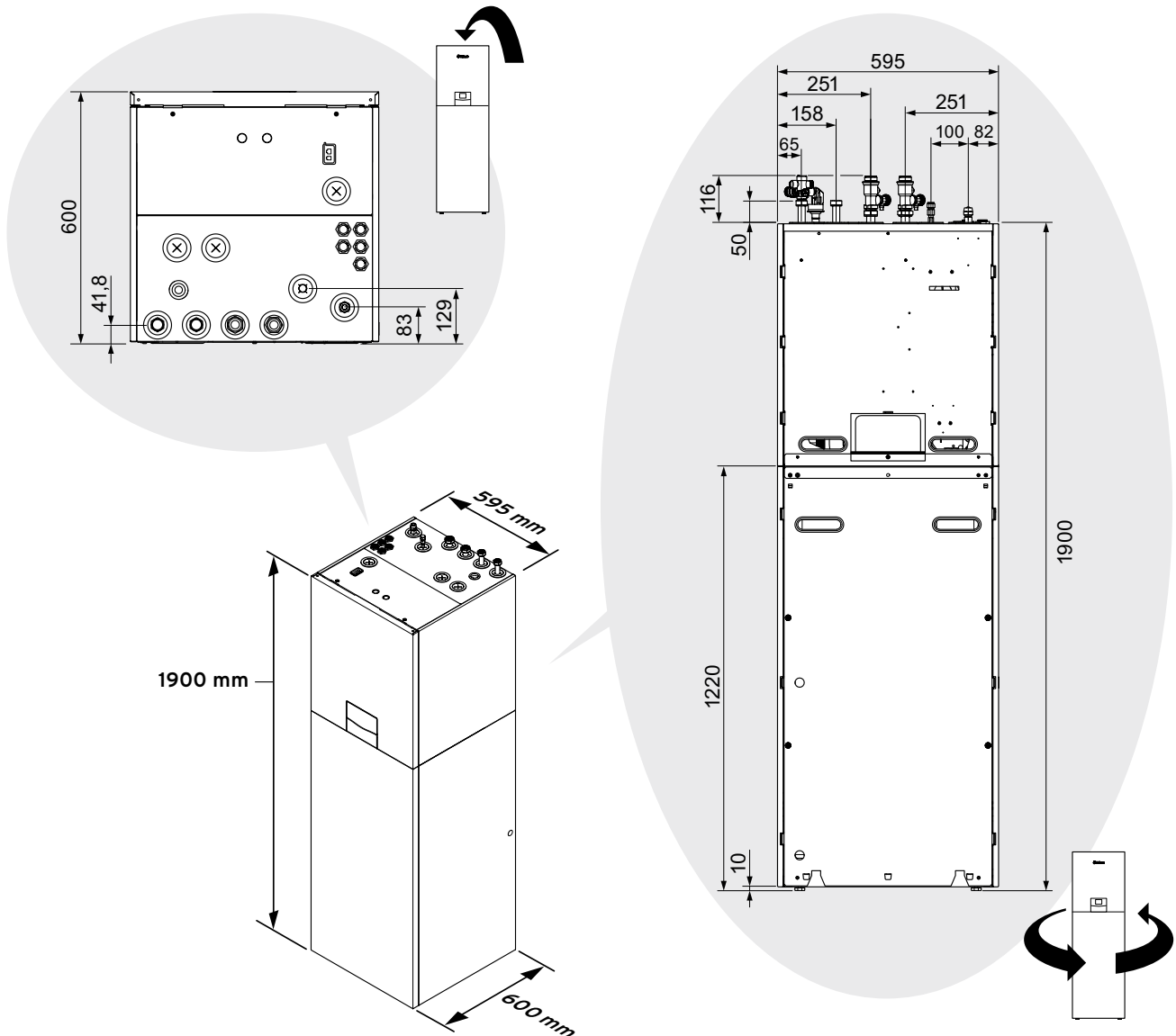



2 heating circuits: Install the uniTOWER pure VWL 108/7.2 IS C2

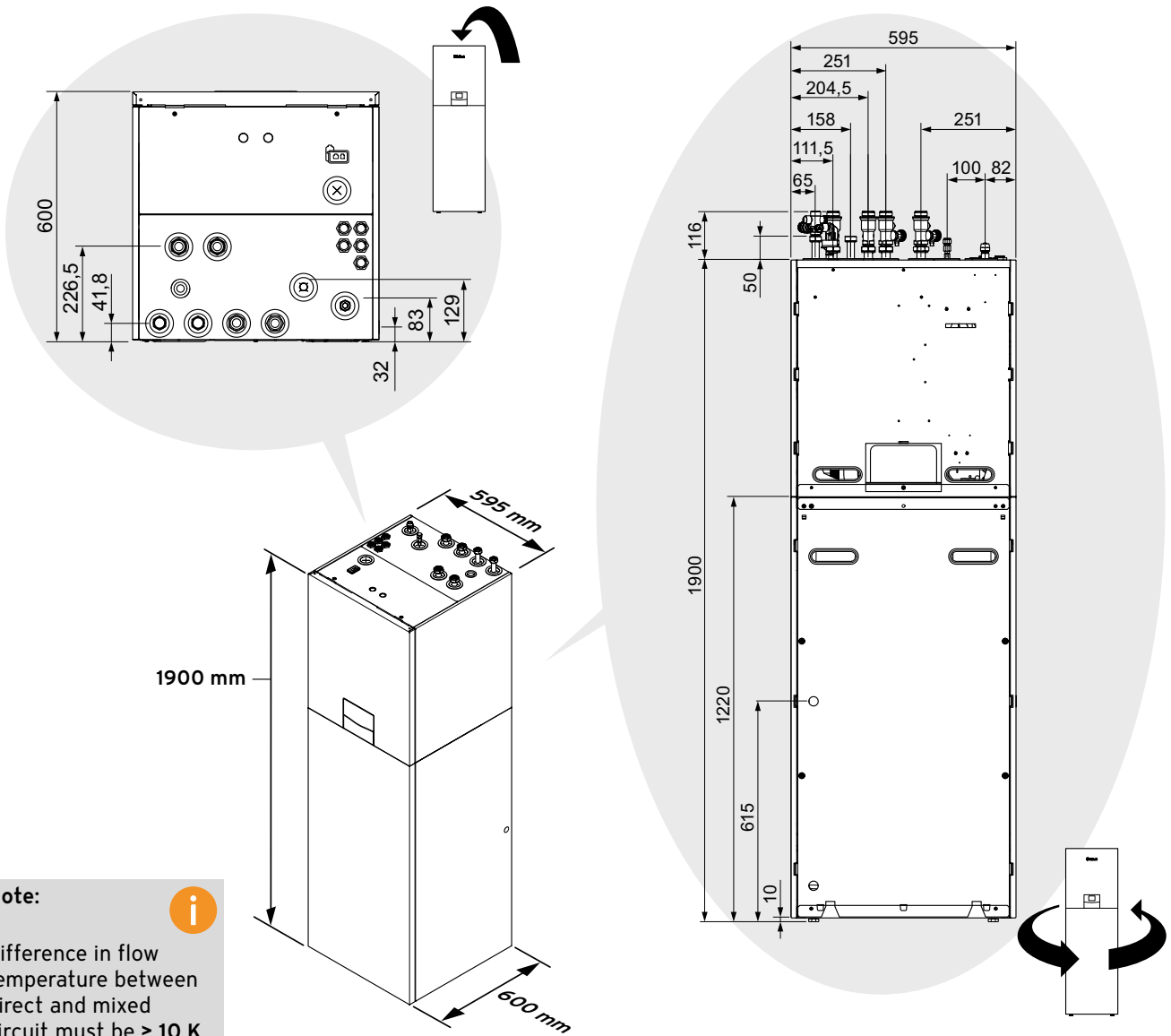

Set the bypass valve (only uniTOWER pure C2)

Scan or click the QR code for assistance with commissioning the uniTOWER pure C2

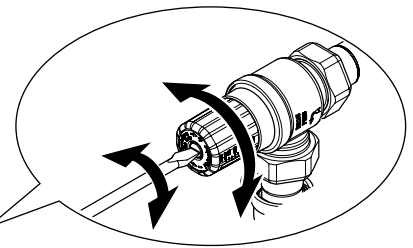
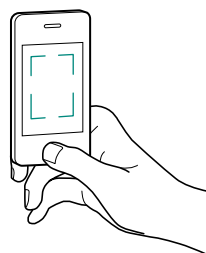

Scan or Click QR-Code to set the bypass valve



Install the hydraulic module

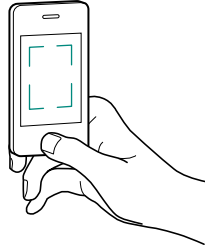
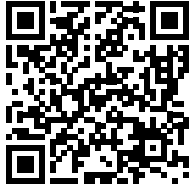

Scan or Click QR-Code for installation video

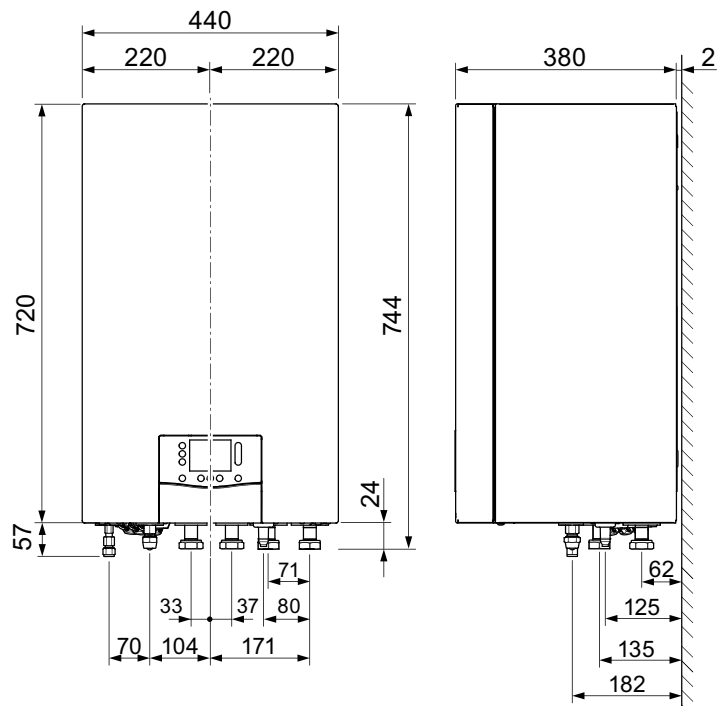
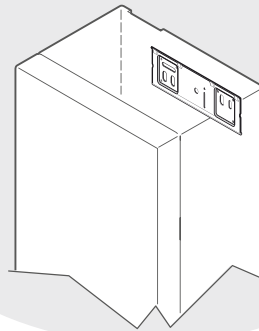
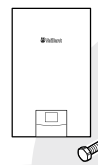
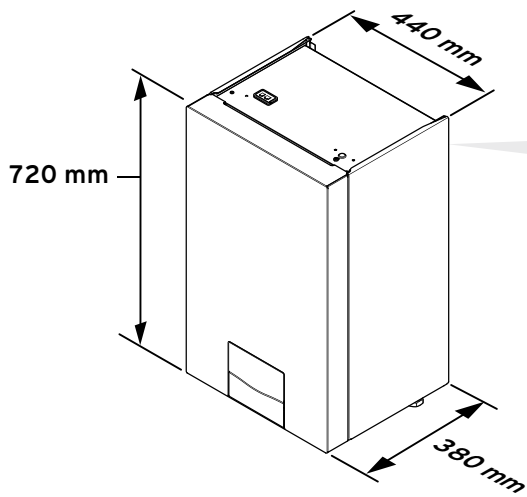



Filling of the refrigerant circuit

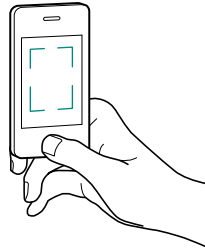

Scan or Click QR-Code for installation video

Amount of refrigerant to be filled up

—●— VWL 45/7.2 AS, VWL 65/7.2 AS, VWL 85/7.2 AS, VWL 105/7.2 AS

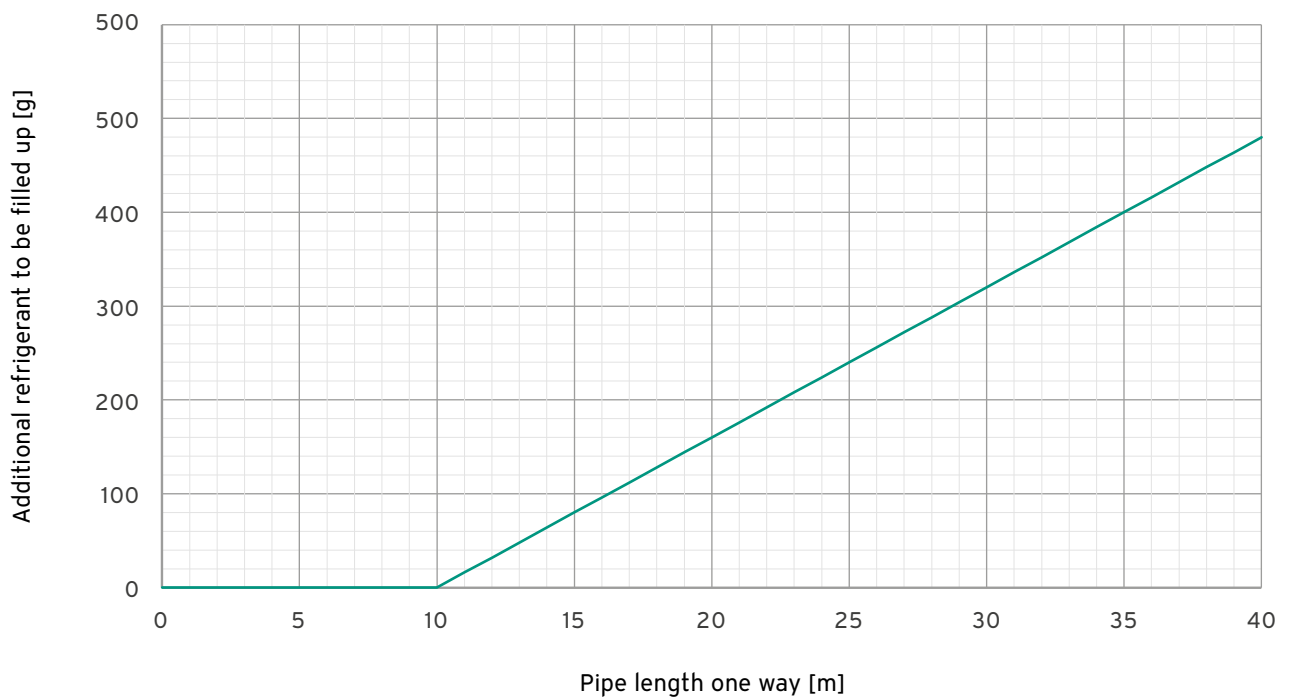



Check your installation!

Tick your installation checklist

- Heat pump positioned according to type of installation (ground, wall, roof)
- Refrigerant pipes bent and connected
- Tightness of refrigerant circuit checked
- Refrigerant circuit evacuated
- Optional: Additional refrigerant filled up
- Refrigerant released from outdoor unit into refrigerant circuit
- Safety valve installed
- Expansion vessel installed and connected
- Manometer installed
- All valves installed in system
- Hydraulic connected and tight (pressure test performed)
- Wiring connection done
- Heating system vented
- For uniTOWER pure VWL 108/7.2 IS **C2** - bypass valve set
- Optional: Warranty extension/ maintenance and service contract signed



... and start your System

Scan the QR code to easily set up the system ...



Just in case ...

Find remedies to error, status and maintenance codes

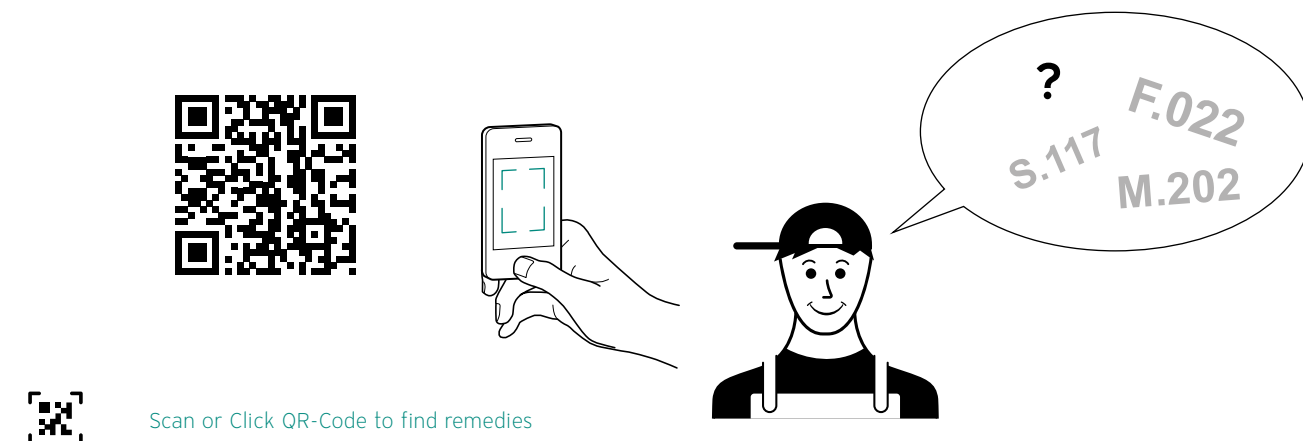

Scan or Click QR-Code to find remedies



Technical Data - Outdoor Unit

aroTHERM pure	VWL 45/7.2 AS	VWL 65/7.2 AS	VWL 85/7.2 AS	VWL 105/7.2 AS
Rated voltage (+10%/- 15%), 50 Hz	230 V 1~/N/PE	230 V 1~/N/PE	230 V 1~/N/PE	230 V 1~/N/PE
Rated power, maximum	2.3 kW	2.3 kW	4.4 kW	5.1 kW
Rated power factor	0.99			
Rated current, maximum	10.0 A	10.0 A	19.0 A	22.0 A
IP rating	IPX4			
Refrigerant circuit				
Max. height difference if outdoor unit is above indoor unit	30 m			
Max. length of refrigerant pipe if outdoor unit is above indoor unit	40 m			
Max. height difference if indoor unit is above outdoor unit	15 m			
Max. length of refrigerant pipe if indoor unit is above outdoor unit	20 m		25 m	
Refrigerant, fill quantity	1.0 kg		1.6 kg	
Heating output / Cooling output				
A-7/W35	4.12 kW	4.73 kW	6.41 kW	7.12 kW
A2/W35	4.81 kW	5.31 kW	7.16 kW	7.67 kW
A7/W35	4.21 kW	6.07 kW	7.88 kW	9.85 kW
A7/W45	3.80 kW	5.95 kW	7.95 kW	9.49 kW
A7/W55	4.32 kW	6.08 kW	6.71 kW	7.40 kW
A35/W7 (Cooling)	3.61 kW	5.14 kW	6.37 kW	7.32 kW
A35/W18 (Cooling)	4.0 kW	5.90 kW	7.04 kW	7.16 kW
Coefficient of performance COP, EN 14511 (heating) / Energy efficiency ratio EER, EN 14511 (cooling)				
A-7/W35	3.00 kW	2.96 kW	2.93 kW	2.86 kW
A2/W35	3.80 kW	3.72 kW	3.39 kW	3.38 kW
A7/W35	5.31 kW	5.05 kW	4.65 kW	4.68 kW
A7/W45	3.64 kW	3.98 kW	3.53 kW	3.55 kW
A7/W55	2.91 kW	3.28 kW	3.14 kW	3.19 kW
A35/W7 (Cooling)	2.97 kW	2.87 kW	2.81 kW	2.44 kW
A35/W18 (Cooling)	4.96 kW	4.25 kW	3.96 kW	3.76 kW
Power consumption, effective				
A-7/W35	1.37 kW	1.60 kW	2.19 kW	2.49 kW
A2/W35	1.26 kW	1.43 kW	2.11 kW	2.27 kW
A7/W35	0.79 kW	1.20 kW	1.70 kW	2.11 kW
A7/W45	1.04 kW	1.50 kW	2.25 kW	2.67 kW
A7/W55	1.48 kW	1.85 kW	2.14 kW	2.32 kW
A35/W7 (Cooling)	1.21 kW	1.79 kW	2.27 kW	3.00 kW
A35/W18 (Cooling)	0.81 kW	1.39 kW	1.78 kW	1.90 kW



Technical Data - uniTOWER pure

	VWL 108/7.2 IS	VWL 108/7.2 IS C2	VWL 108/7.2 IS S5
Rated voltage 230 V (+10%/- 15%), 50 Hz	230 V 1~/N/PE		
Rated voltage 400 V (+10%/- 15%), 50 Hz	400 V 3~/N/PE		
Rated power, maximum	5.5 kW	5.5 kW	5.5 kW
IP rating	IP 10 B		
Heating circuit			
Heating water temperature, minimum/maximum	20 ... 60 °C		
Water content	21 l	23 l	21 l
Operating pressure, minimum	0.05 MPa (0.50 bar)		
Operating pressure, maximum	0.30 Mpa (3.00 bar)		
DHW circuit			
Water capacity hot water tank	188 l		
Cylinder temperature by heat pump max.	55 °C		
Cylinder temperature by electric backup heater max.	70 °C		
Time to reheat cylinder to 52 °C at A7 (4/6 kW outdoor unit)	65 min		
Time to reheat cylinder to 52 °C at A7 (8/10 kW outdoor unit)	55 min		

Technical Data - hydraulic module

	VWL 107/7.2 IS	VWL 107/7.2 IS S1
Rated voltage 230 V (+10%/- 15%), 50 Hz	230 V 1~/N/PE	
Rated voltage 400 V (+10%/- 15%), 50 Hz	400 V 3~/N/PE	
Rated power, maximum	5.5 kW	5.5 kW
IP rating	IP 10 B	
Heating circuit		
Heating water temperature, minimum/maximum	20 ... 60 °C	
Water content	6 l	6 l
Operating pressure, minimum	0.05 MPa (0.50 bar)	
Operating pressure, maximum	0.30 Mpa (3.00 bar)	



Vaillant GmbH

Berghauser Str. 40 ■ D-42859 Remscheid
Tel. +49 21 91 18-0 ■ Fax +49 21 91 18-28 10
www.vaillant.de ■ info@vaillant.de